

sunways

EN

User Manual

Hybrid Inverter

STH 15-33KTL-HT

sunways

CONTENTS

1 Preface	5
1.1 Overview	5
1.2 Target Groups	5
2 Safety Instructions	6
2.1 Safety Notes	6
2.2 Statement	6
2.3 Important Safety Matters	7
2.4 Symbols Explanation	8
3 Product Description	11
3.1 Basic Features	11
3.2 Physical Layout	16
3.3 Display Interface	18
3.4 Packing List	19
4 Installation	22
4.1 Location	22
4.2 Mounting the Inverter	24
4.3 Electrical Connection	26
4.4 Meter and CT connection	41
4.5 Communication Connection	44
4.6 Monitoring Device Installation	50
5 Start and Stop	51
5.1 Start the Inverter	51
5.2 Stop the Inverter	51
6 General Operation	52
6.1 Display Operation	52
6.2 Country Code (Safety Code) Setting	56
6.3 Auto-Test	56
6.4 Online Monitoring APP	57
7 Troubleshooting	58
7.1 Error Message	58
7.2 Maintenance	63
8 Technical Parameters	64

Attention

The products, services or features purchased are subject to the commercial contracts and terms of Ningbo Sunways Technologies Co., Ltd. All or part of the products, services or features described in this document may not be within your purchasing and using scope. Unless otherwise agreed in the contract, the Company shall not make any express or implied declaration or guarantee of the contents of this document.

Due to product version upgrades or other reasons, the contents of this document will be updated periodically. Unless otherwise agreed, this document serves only as a guide to use, and all statements, information and recommendations in this document do not constitute any express or implied guarantee.

» 1 Preface

※ 1.1 Overview

This manual is an integral part of Sunways STH 15-33kW series three-phase high-voltage hybrid inverters (hereinafter referred to as the inverter). It mainly introduces the assembly, installation, electrical connection, debugging, maintenance and troubleshooting of the products. Before installing and using hybrid inverters, please read this manual carefully, understand the safety information and be familiar with the functions and characteristics of hybrid inverters.

※ 1.2 Target Groups

This manual is applicable to the electrical installers with professional qualifications and the people who bought it. If there are any problems in the installation process, please call Sunways service telephone at +86 400-9922-958 or email Sunways at service@sunways-tech.com for consultation.

» 2 Safety Instructions

※ 2.1 Safety Notes

1. Before installation, please read this manual carefully and follow the instructions in this manual strictly.
2. Installation operator need to undergo professional training or obtain electrical related professional qualification certificates.
3. When installing, do not open the front cover of the inverter. Apart from performing work at the wiring terminal (as instructed in this manual), touching or changing components without authorization may cause injury to people, damage to inverters and annulment of the warranty.
4. All electrical installations must conform to local electrical safety standards.
5. If the inverter needs maintenance, please contact the local designated personnel for system installation and maintenance.
6. To use this grid-connected inverter for power generation needs the permission of the local power supply authority.
7. The temperature of some parts of the inverter may exceed 60° C during operation. To avoid being burnt, do not touch the inverter during operation. Let it cool before touching it.
8. When exposed to sunlight, the PV array generates dangerous high DC voltage. Please operate according to our instructions, or it will result in danger to life.
9. When wiring the lithium battery terminals, please disconnect the breaker or switch of the lithium battery in case of a physical injury caused by the high-voltage.

※ 2.2 Statement



Sunways Technologies Co.,Ltd. has the right not to undertake quality assurance in any of the following circumstances:



1. Damages caused by improper transportation.
2. Damages caused by incorrect storage, installation or use.
3. Damages caused by installation and use of equipment by non-professionals or untrained personnel.

4. Damages caused by failure to comply with the instructions and safety warnings in this document.
5. Damages of running in an environment that does not meet the requirements stated in this document.
6. Damages caused by operation beyond the parameters specified in applicable technical specifications.
7. Damages caused by unauthorized disassembly, alteration of products or modification of software codes.
8. Damages caused by abnormal natural environment (force majeure, such as lightning, earthquake, fire, storm, etc.).
9. Any damages caused by the process of installation and operation which don't follow the local standards and regulations.
10. Products beyond the warranty period.

※ 2.3 Important Safety Matters

Table below shows the symbols that may appear in this document and their definition:





Symbol	Description
	Dangerous situation, if not avoided, it could result in death or serious personal injury.
	Potentially dangerous situation, if not avoided, may result in death or serious personal injury.
	Potentially dangerous situation, if not avoided, may result in moderate or minor personal injury.

Symbol	Description
 Attention	The safety warning information about equipment or environment, to prevent equipment damage, data loss, equipment performance degradation or other unpredictable results.
 Note	Symbol highlights important information, best practices and tips, etc.

※ 2.4 Symbols Explanation





This chapter mainly elaborates the symbols displayed on the inverter, nameplate and packing box.



▼ 2.4.1 2.4.1 Symbols on the Inverter

Symbol	Description
	Power indicator.
	Grid status indicator.
	Inverter status indicator.
	Battery level indicator.





Symbol	Description
	Grounding symbol, the inverter casing needs to be properly grounded.

▼ 2.4.2 Symbol on the Inverter nameplate

Symbol	Description
	The inverter cannot be disposed of with household waste.
	Please read the instructions carefully before installation.
	Do not touch any internal parts of the inverter until 5 min after being disconnected from the mains and PV input.
	CE mark, the inverter complies with the requirements of the applicable CE guidelines.
	TUV certification.
	Danger. Risk of electric shock!

Symbol	Description
	The surface is hot during operation and no touch is allowed.
	Electric shock hazard, live parts, risk of electric shock, do not touch.

▼ 2.4.3 Symbol on the Packing box

Symbol	Description
	Handle with care.
	This side up.
	Keep dry.
	Stacked layers.

» 3 Product Description

※ 3.1 Basic Features

▼ 3.1.1 Function

The Sunways STH series inverter is also known as hybrid inverter or storage inverter, which is mainly used to combine the PV array, lithium battery, loads and power grid to realize intelligent power management and dispatching.

▼ 3.1.2 Models

The STH 15-33kW series hybrid inverter includes 7 models which are listed below:

STH-15KTL-HT、STH-17KTL-HT、STH-20KTL-HT、STH-25KTL-HT、STH-29.9KTL-HT、STH-30KTL-HT、STH-33KTL-HT.

▼ 3.1.3 Applicable grid type

The applicable grid types of the Sunways STH 15-33kW series are TN-S, TN-C, TN-C-S and TT. When applied to the TT grid, the voltage of N to PE should be less than 30V. See Figure 3-1 for details:

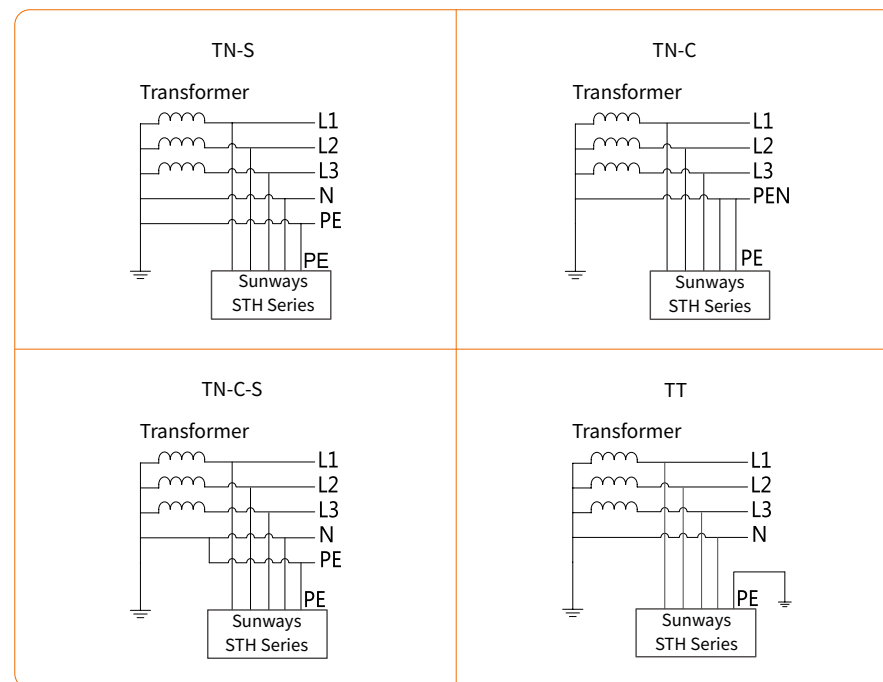

Figure 3-1 Applicable grid types

3.1.4 Schematic diagram of hybrid system

The hybrid solar system is usually composed of the PV array, hybrid inverter, lithium battery, loads and power grid. As shown in the Figure 3-2:

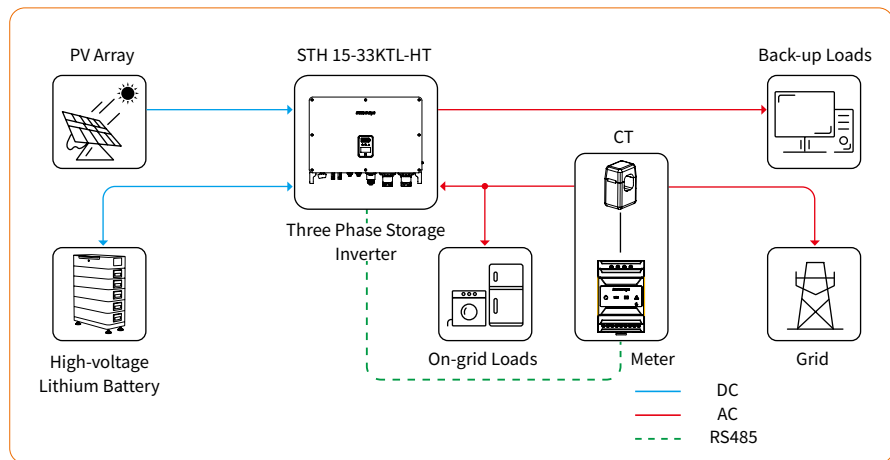

Figure 3-2 Schematic diagram of hybrid system

3.1.5 Operation modes

Sunways STH Hybrid inverter has the following basic operation modes and you can configure the operation mode as per your preference in the App.

Mode 1

In this working mode, when the power from the PV array is sufficient, PV power will supply the loads, battery, and grid by the following sequence:

Loads > Battery > Grid.

PV power will supply the loads first, and secondly charge the battery, and then feed to the grid.

(You can set the power to the grid to 0W if the local grid doesn't allow).

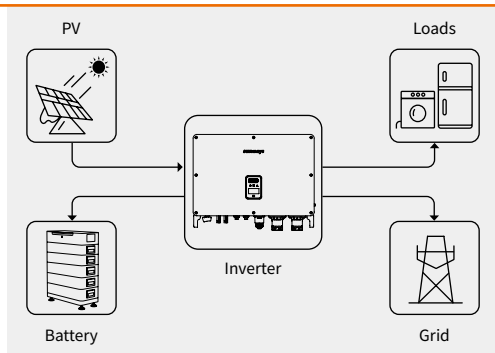

When the PV power is insufficient, the battery will discharge to supply loads, and the grid will join in if the battery is not enough to supply loads.

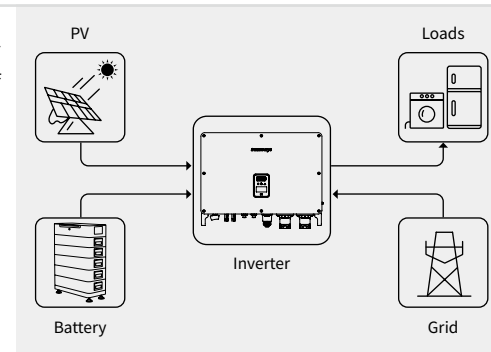

Mode 2

Screen Setting step:

1. General Settings → WorkMode Set → General Mode
2. Advanced Settings → Peakload Shifting → ON
3. Advanced Settings → Set MaxGrid → XXX (kVA)

APP Setting step:

General Mode → To Set → Peakload Shifting ON → Set Max Grid (kVA)

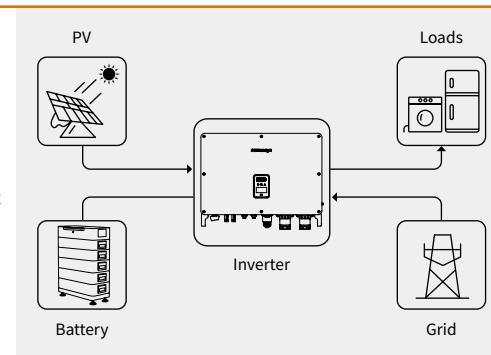

In this working mode, set the Pmax from grid in the App can realize the “Peakload Shifting”.

When the loads consumption more than the Pmax, the power exceeded Pmax (cannot be higher than the inverter max output power) will be supplied by the inverter.

Inverter will use power from PV array to supply loads first and battery second if it isn't enough.

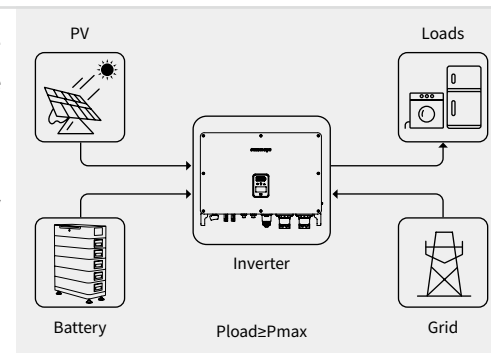

*To realize the “Peakload Shifting” function, the load power that exceeded Pmax has to be within the inverter max output power, otherwise, the inverter will only output the max power which allowed.

Mode 3

In this working mode, the inverter will use the power from PV or grid (Set in the App) to charge the battery until it is fully charged, and as long as the grid is there, the battery won't discharge. When the grid is cut off, power from PV and battery will supply loads connected in the back-up side (UPS).

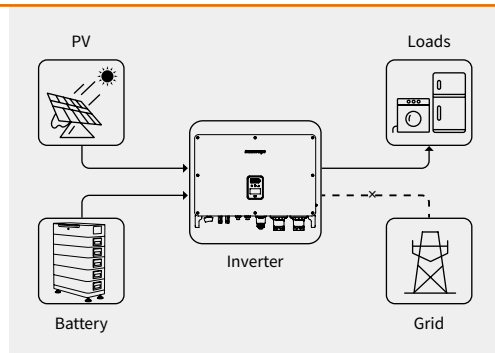

Mode 4

In this working mode, you can set charge/discharge power and time in the App, inverter will use the power from PV or grid (whether to use can be set in the App) to charge the battery in the predetermined period.

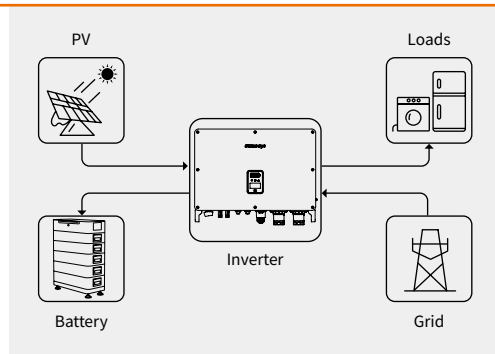

Inverter will use power from PV and battery to supply loads in the predetermined period and the insufficient part will be supplied by the grid.

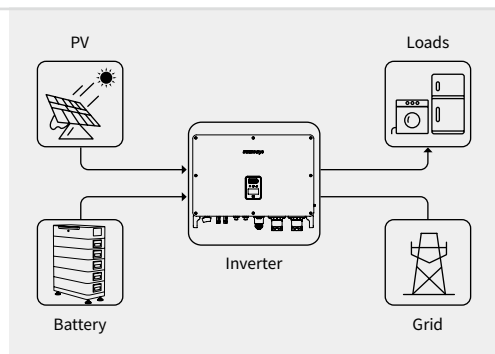

Mode 5

In the purely off-grid mode, power from PV will supply the back-up loads first and then charge the battery if there's surplus.

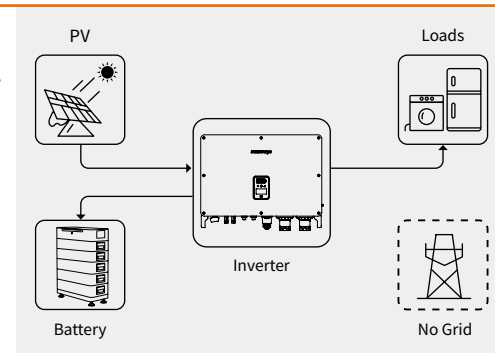

When the power from PV isn't enough, the battery will discharge to supply back-up loads together with PV.

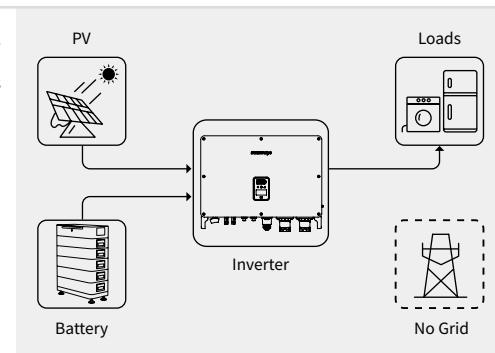

3.1.6 Off-grid output ability (UPS ability)

Sunways STH hybrid inverter overloading ability in off-grid work mode describes as following:

Off-grid Overloading Ability Illustration

Status	Mode	Phase 1	Phase 2	Phase 3	Duration
Off-grid	Balance Output Mode	1.1 times	1.1 times	1.1 times	Continuous
		2 times	2 times	2 times	60s
	Unbalance Output Mode	1.25 times**	1.25 times**	1.25 times**	Continuous

* The multiples above are calculated based on rated output power.

**Only one of the three phases can reach up to 1.25times, and the other two phases should be less than 1.1times.

▼ 3.1.7 Storage conditions

- 1) Inverter must be stored in its original packaging.
- 2) The storage temperature and humidity should be in the range of -30°C and +60°C, and less than 90%, respectively.
- 3) If a batch of inverters needs to be stored, the height of each pile should be no more than 4 levels.

※ 3.2 Physical Layout

▼ 3.2.1 Inverter front view

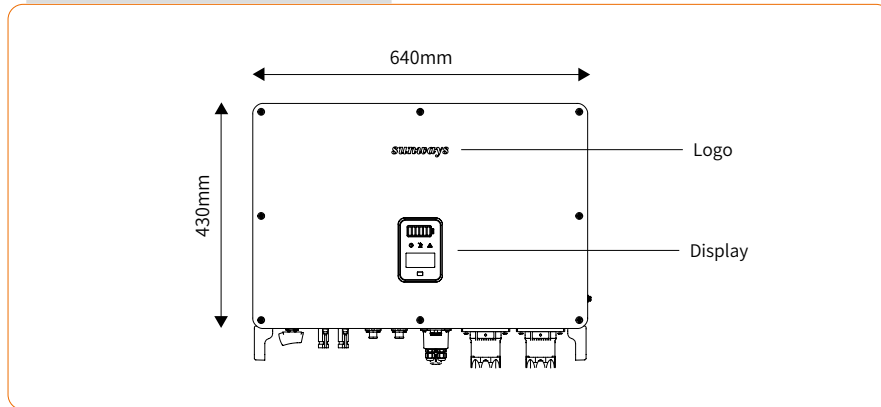

Figure 3-3 Front view

▼ 3.2.2 Inverter side view

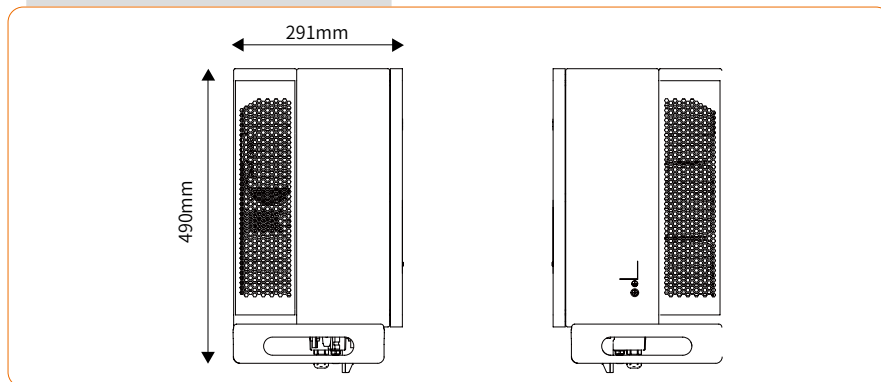

Figure 3-4 Side view

▼ 3.2.3 Inverter bottom view

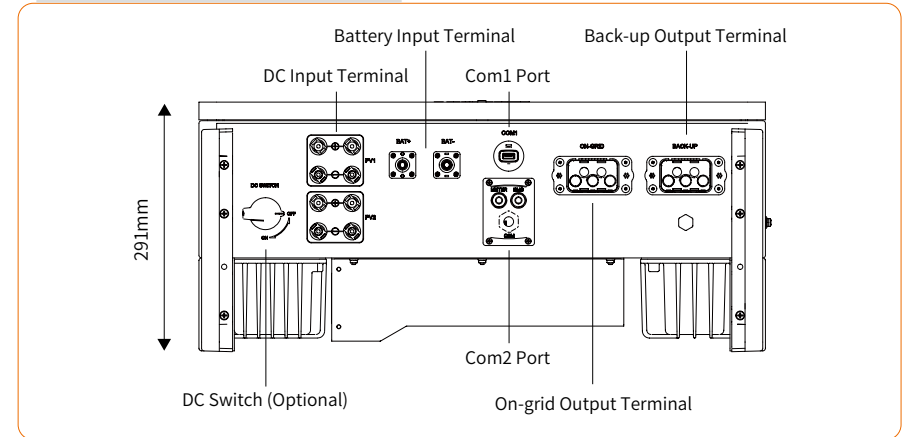

Figure 3-5 Bottom view

Wiring terminals are at the bottom of the inverter, as shown in the table below.

Item	Terminal	Note
1	DC Input Terminal	PV connector
2	Battery Input Terminal	Battery connector
3	COM1 Port	WiFi/LAN/GPRS/4G device connector
4	COM2 Port	Meter/BMS/RS485/DRED connector
5	On-grid Output Terminal	Used for On-grid output cable connection
6	Back-up Output Terminal	Used for Back-up output cable connection

3.2.4 Inverter back view

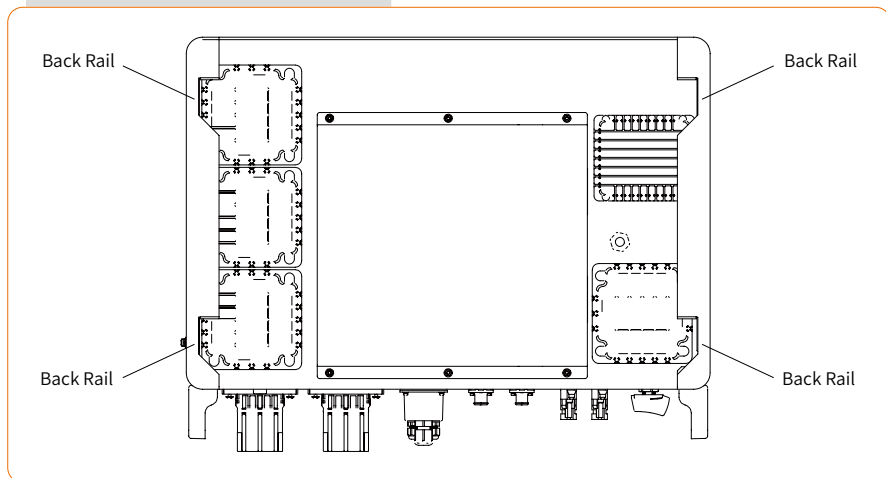

Figure 3-6 Inverter back view

※ 3.3 Display Interface

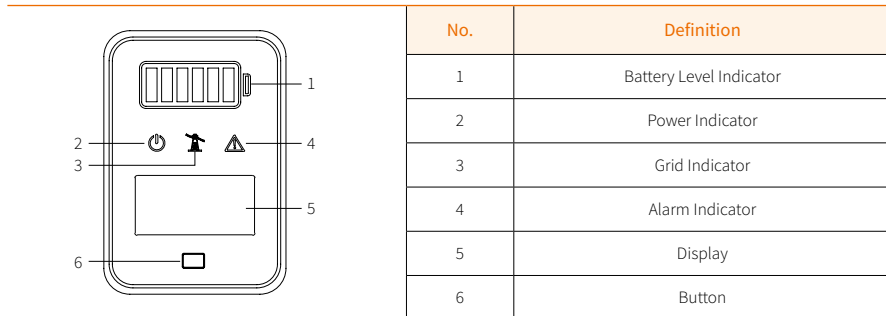

Figure 3-7 Display interface

Item	Indicator	Status	Description
1	Battery Level Indicator	Off	Battery not connected or communication fault.
		Always on	Battery is discharging or waiting, indicator shows battery level.
		Single indicator flash	Battery is charging, indicator shows battery level.

Item	Indicator	Status	Description
2	Power Indicator	Off	Inverter no AC output.
		Quick flashing	Inverter entered self-test status.
		Slow flashing	Inverter entered waiting status.
		Always on	Inverter works normal.
3	Grid Indicator	Off	Disconnected with grid.
		Slow flashing	Inverter detected grid but not running in on-grid mode.
		Always on	Inverter works in on-grid mode.
4	Alarm Indicator	Off	The inverter is running normally.
		Slow flashing	The monitoring device is not connected to the router or is not connected to the base station.
		Quick flashing	The monitoring device is connected to the router or connected to the base station but not connected to the server.
		Orange	A Warning is detected but inverter still working, view the fault info on the display.
		Red	An alarm or fault is detected, view the fault info on the display.
5	Display	On	Display the inverter operation information.
		Off	Display off to save power, press the button to wake up the display.
6	Button	Physical button	Switch display information and set parameters by short press or long press.

※ 3.4 Packing List

The package of the inverter includes the following accessories. Please check whether the accessories in the packing box are complete when receiving the goods. See Figure 3-7 for the packing list.

▼ Inverter×1

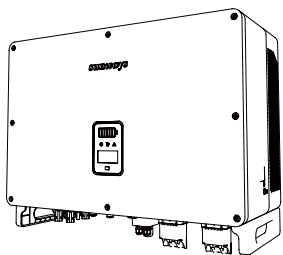

▼ Back Bracket×1

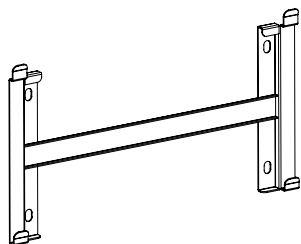

▼ PE Terminal



PE Terminal× 1

▼ Battery Plug

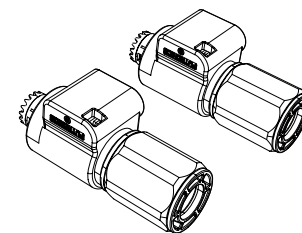

Battery Plug× 1

▼ PV Terminal

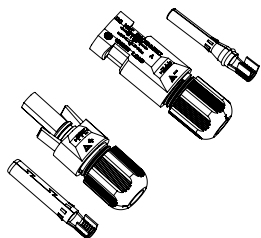

PV Terminal × 4

▼ M10 Bracket Screw

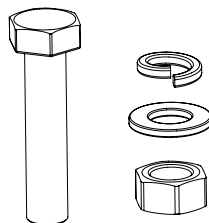

M10 Bracket Screw × 4

▼ 6Pin Terminal

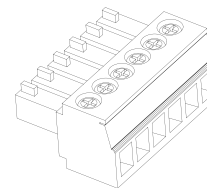

6Pin Terminal × 2

▼ Monitoring Device (Optional)

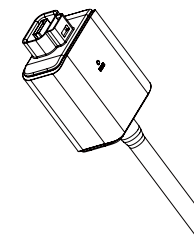

Monitoring Device (Optional) × 1

▼ Sunways Meter A (Optional)

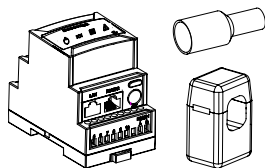

Sunways Meter A with 3 CTs×1
Cord End Terminal × 8

▼ Sunways Meter B (Optional)

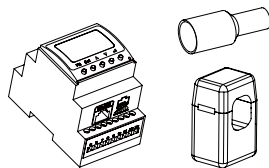

Sunways Meter B with 3 CTs×1
Cord End Terminal × 8

▼ AC Terminal

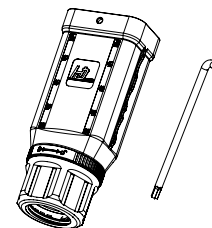

AC Terminal × 2

▼ Inspection Report



Inspection Report × 1

Figure 3-8 Packing list

» 4 Installation

※ 4.1 Location

The Sunways STH 15-33kW series inverters designed with IP65 protection enclosure for indoor and outdoor installations. When selecting an inverter installation location, the following factors should be considered:

- 1) The wall or installation bracket on which the inverters mounted must be able to withstand the weight of the inverter.
- 2) The inverter needs to be installed in a well-ventilated environment.
- 3) Do not expose the inverter directly to strong sunlight to prevent excessive temperature operation. The inverter should be installed in a place with shelter to prevent direct exposure to sunlight and rain.
- 4) Install the inverter at eye level for easy inspection of screen data and further maintenance.
- 5) The ambient temperature of the inverter installation location should be between -30°C and 60°C .
- 6) The surface temperature of the inverter may reach up to 75°C . To avoid risk of burns, do not touch the inverter while it's operating and inverter must be installed out of reaching of children.

▼ 4.1.1 Installation location

Recommended installation location of the inverter, as shown in Figure 4-1:

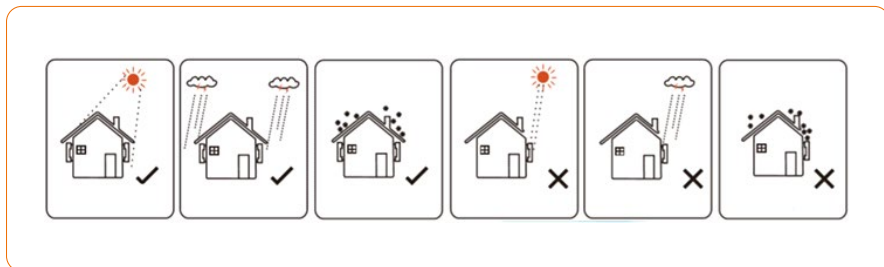

Figure 4-1 Recommended installation location



Warning

Do not put flammable and explosive articles around the inverter.

▼ 4.1.2 Installation spacing

The requirements for inverter installation spacing are shown in Figure 4-2:

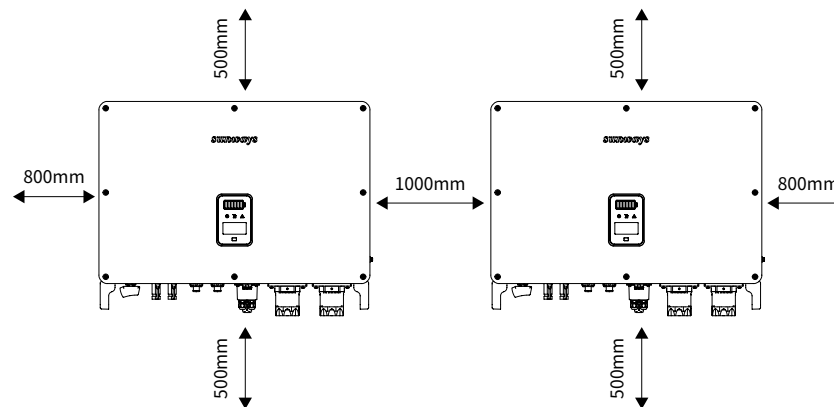

Figure 4-2 Recommended installation spacing

▼ 4.1.3 Installation angle

The installation angle of the inverter is recommended as shown in Figure 4-3:

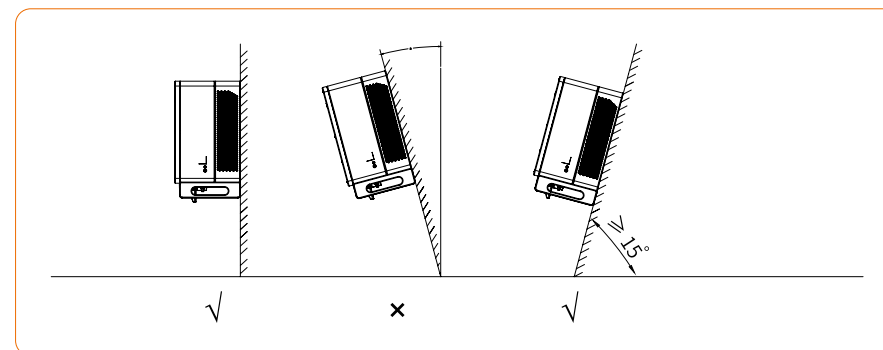

Figure 4-3 Recommended installation angle

※ 4.2 Mounting the Inverter

▼ 4.2.1 Wall bracket installation

Dimensions of wall bracket, see Figure 4-4:

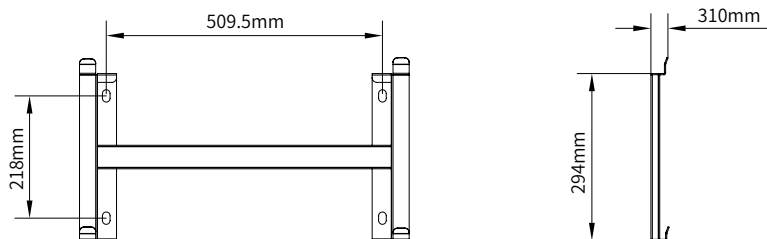

Figure 4-4 Dimensions of wall bracket

- 1) Use the inverter back bracket as the template to mark the position of 4 holes on the installation bracket.
- 2) Use an electrical drill with 12mm diameter bit to drill 4 holes on the installation bracket. See Figure 4-5 for details:

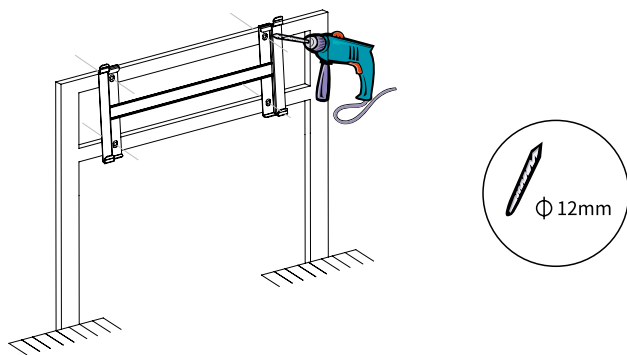

Figure 4-5 Mark the hole position and drill holes

- 3) Follow the instructions in the picture below to install the M10 bracket screws (bolt, spring washer, flat washer) and tighten the bolts with torque wrench in the torque of 35-40N.m, see Figure 4-6 for details:

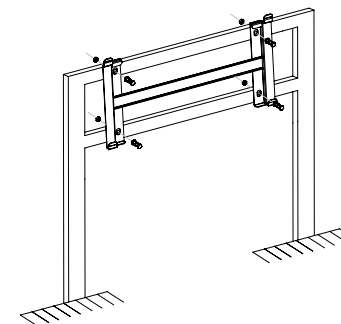

Figure 4-6 Fixing the bracket

▼ 4.2.2 Mounting the inverter

Lift the inverter, hang the back rail on the fixed back bracket carefully. See Figure 4-7 for details:

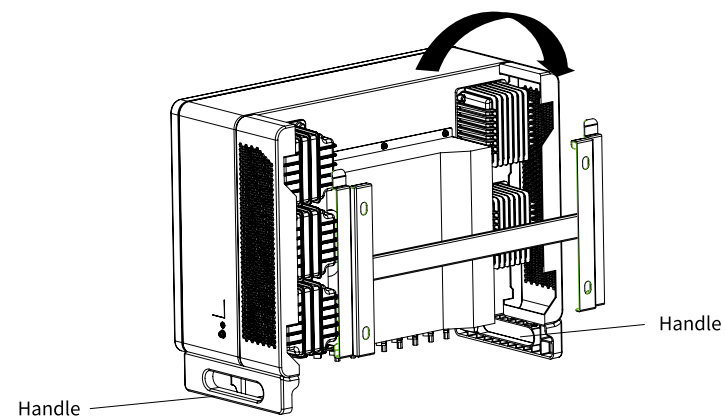







Figure 4-7 Mounting the inverter

※ 4.3 Electrical Connection

Symbol	Description
 Danger	A high voltage in the conductive part of the inverter may cause an electric shock. When installing the inverter, make sure that the AC and DC sides of the inverter are completely de-energized.
 Warning	Do not ground the positive or negative pole of the PV string, otherwise it will cause serious damage to the inverter.
 Warning	Static may cause damage to the electronic components of the inverter. Anti-static measures should be taken during installation and maintenance.
 Attention	Do not use other brands or other types of terminals other than the terminals in the accessory package. Sunways has the right not to undertake quality assurance for all damages caused by the mixed-use of terminals.
 Attention	Moisture and dust can damage the inverter, ensure the cable gland is securely tightened during installation. The warranty claim will be invalidated if the inverter damaged by the cable connector not well installed.

▼ 4.3.1 Sunways STH hybrid inverter electrical wiring diagram

This diagram shows Sunways STH 15~33kW series hybrid inverter wiring structure and composition, concerning the real project, the installation and wiring have to be in line with the local standards.

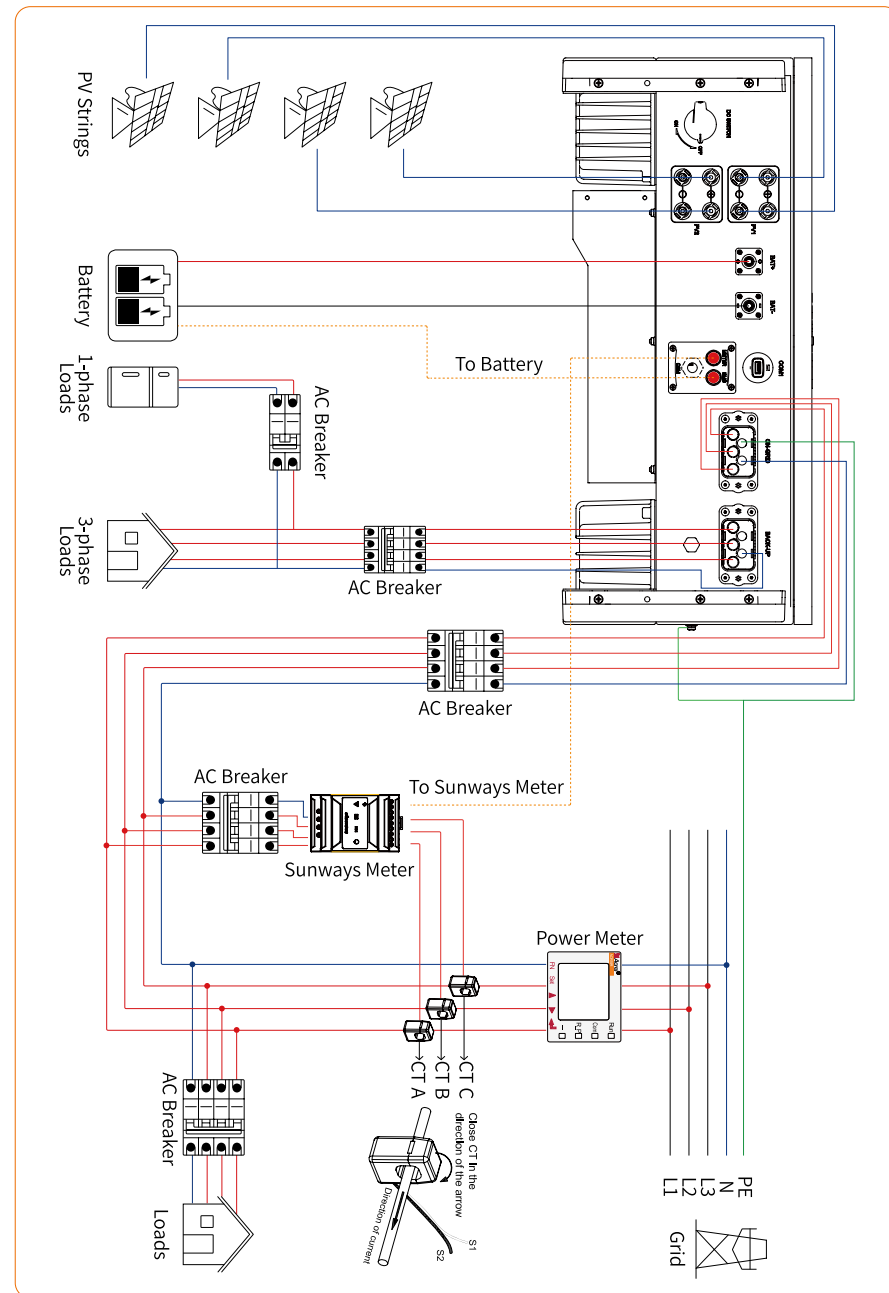

Figure 4-8

Single inverter wiring diagram

This diagram is an example without special requirement on electrical wiring connection.

Neutral line of AC supply can be isolated or switched.

If you get Sunways meter A, please refer to Figure 4-9A:

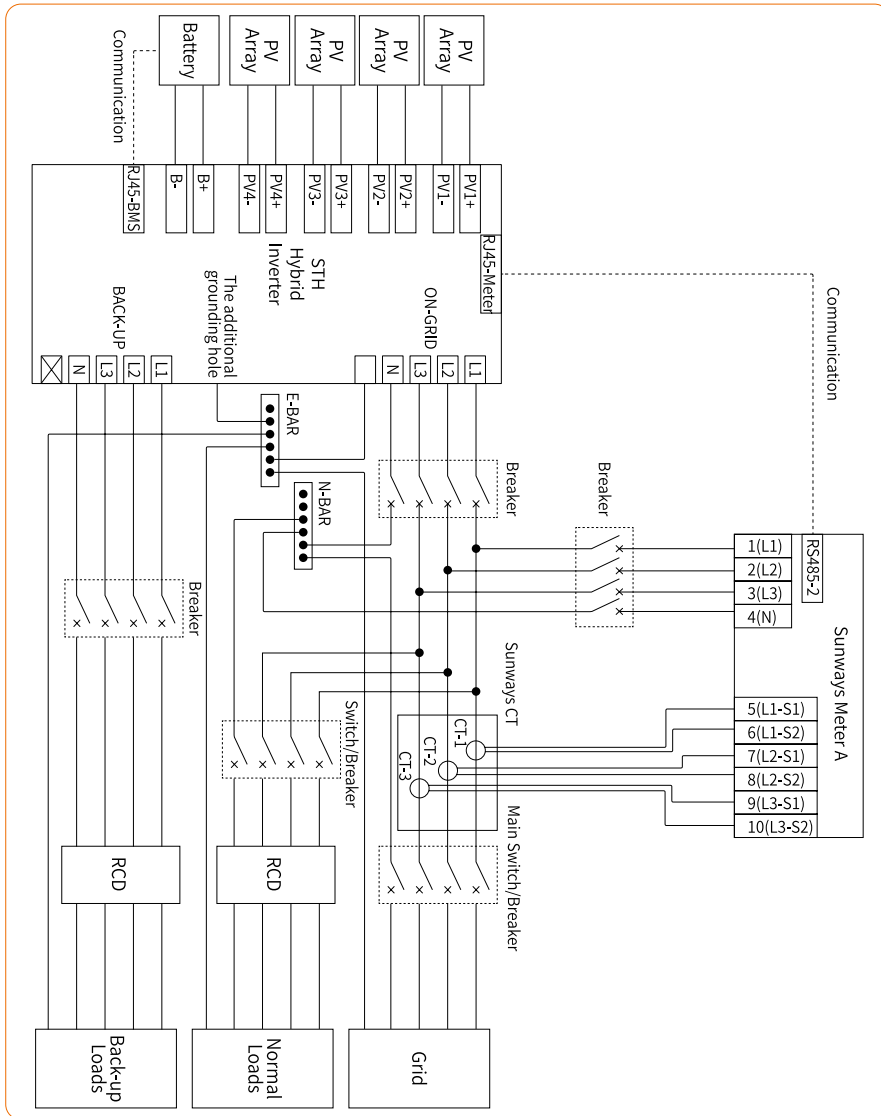

Figure 4-9A Standard wiring diagram

If you get Sunways meter B, please refer to Figure 4-9B:

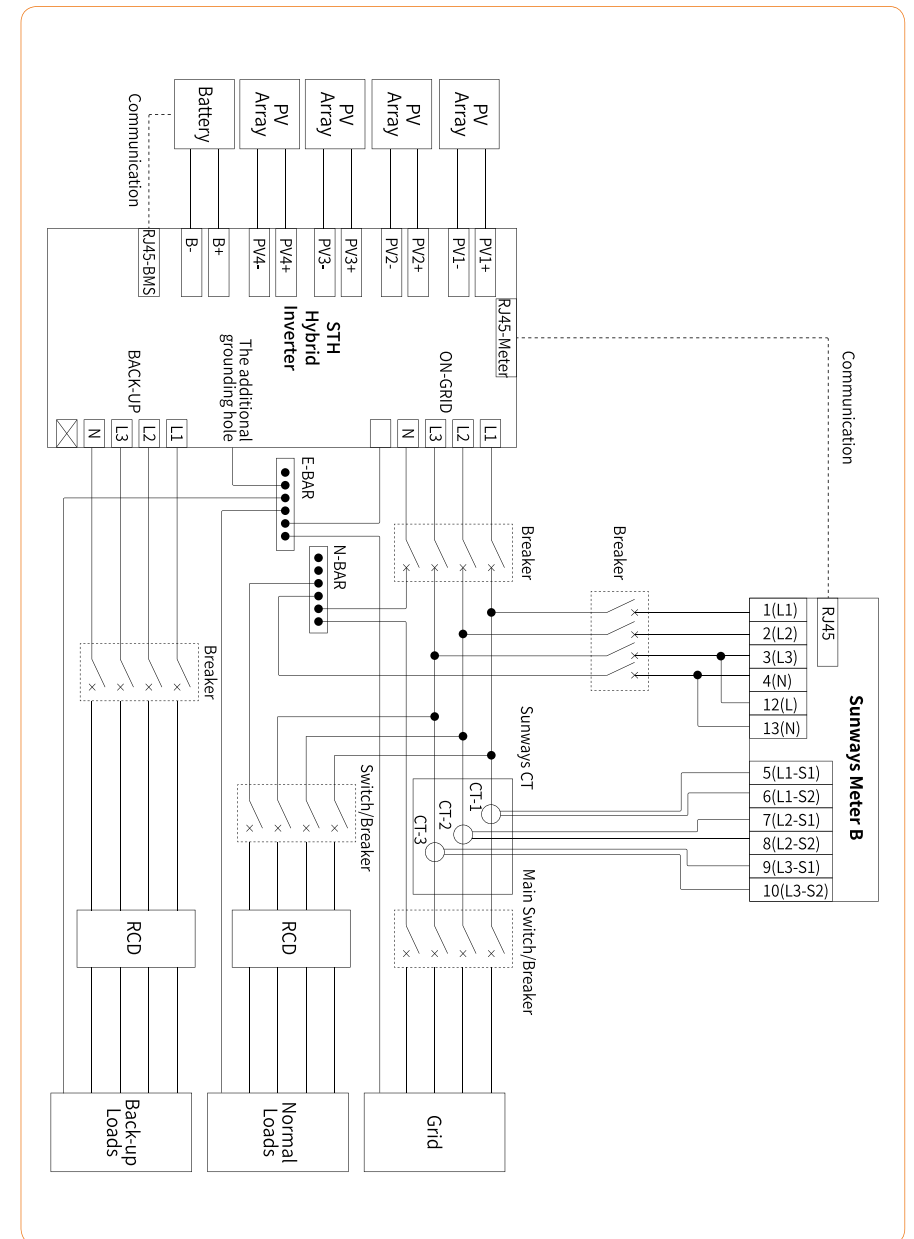

Figure 4-9B Standard wiring diagram

This diagram is an example for Australia and New Zealand. Neutral line of AC supply must not be isolated or switched.

For Sunways meter A, please refer to Figure 4-10A:

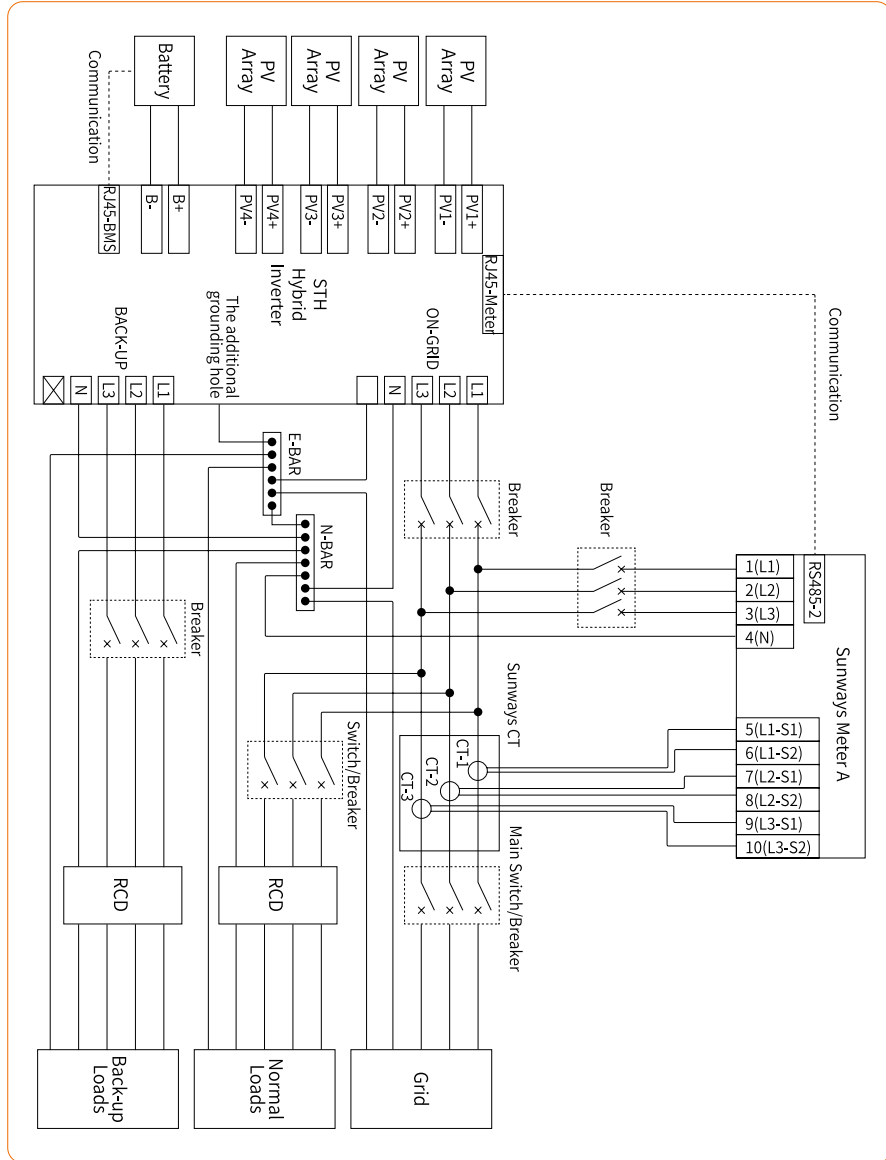

Figure 4-10A Australia wiring diagram

For Sunways meter B, please refer to Figure 4-10B:

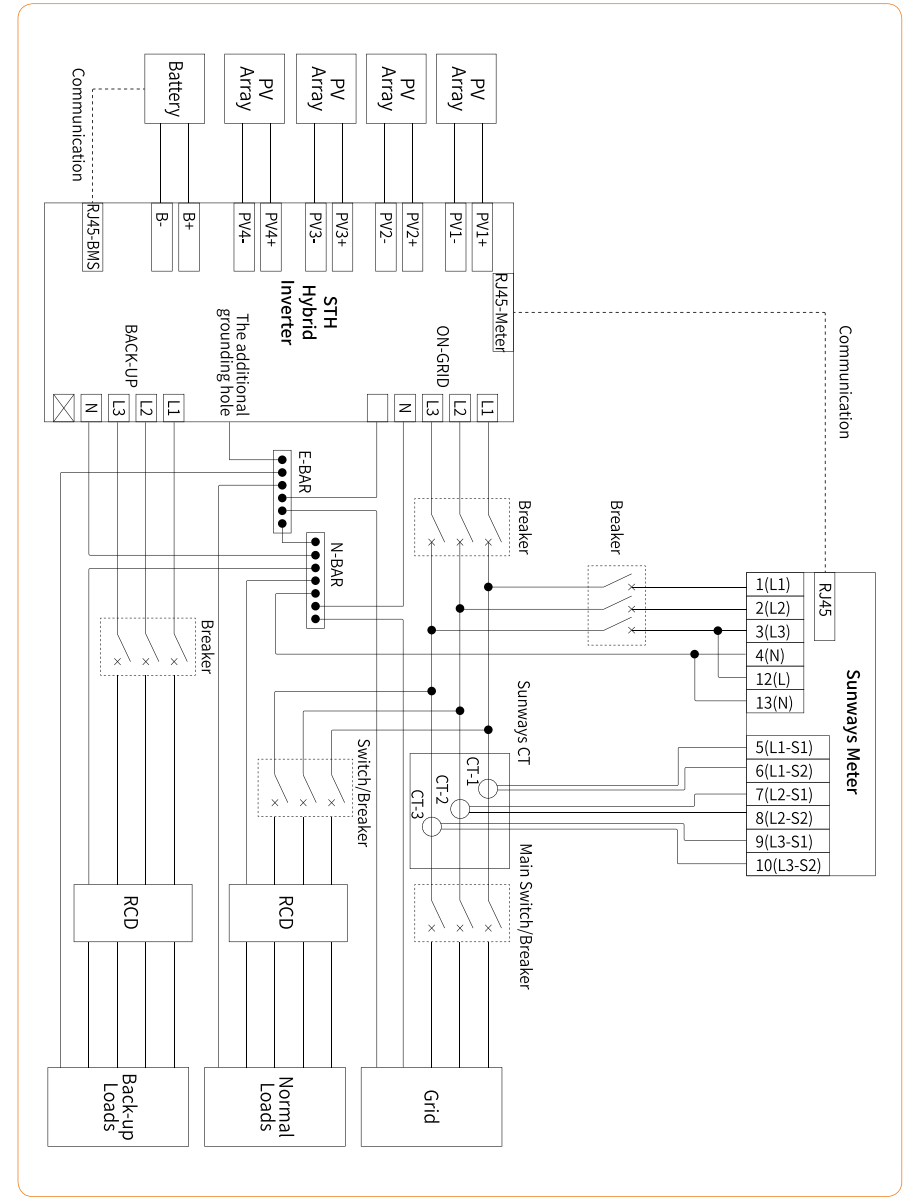



Figure 4-10B Australia wiring diagram

▼ 4.3.2 External ground connection

 <p>Danger</p>	<p>Do not connect the N-wire as a protective ground wire to the inverter casing. Otherwise, it may cause electric shock.</p>
 <p>Attention</p>	<p>Good grounding is good for resisting surge voltage shock and improving EMI performance. Inverters must be well-grounded. For a system with only one inverter, just ground the PE cable. For a multi-inverter system, all inverters PE wire need to be connected to the same grounding copper bar to ensure equipotential bonding.</p>

Ground terminal connection steps:

- 1) The external grounding terminal is located in the lower right side of the inverter.
- 2) Fix the grounding terminal to the PE wire with a proper tool and lock the grounding terminal to the grounding hole in the lower right side of the inverter, as shown in Figure 4-11.

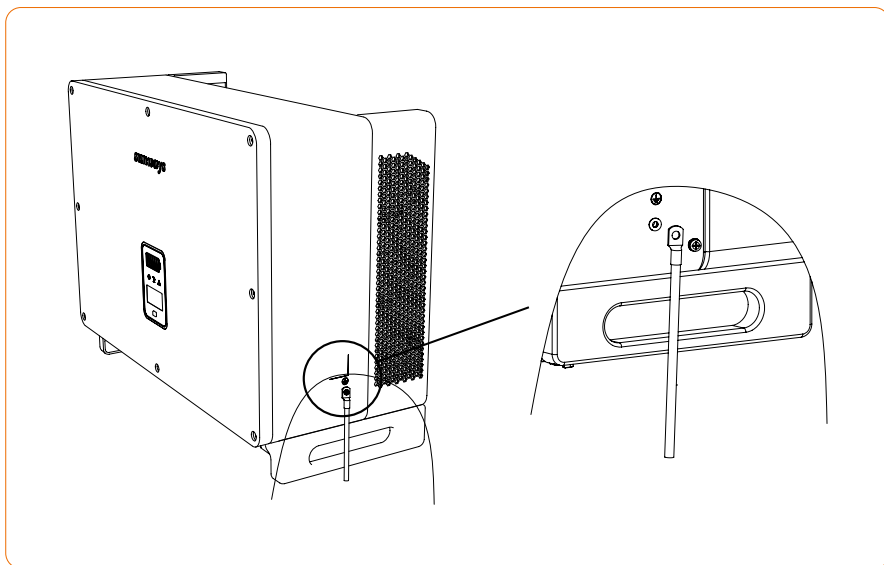

Figure 4-11 Grounding terminal connection

▼ 4.3.3 Inverter PV string connection

1. The following must be considered when making electrical connections to the inverter:

- 1) Disconnect the AC breaker switch on the grid side.
- 2) The DC switch of the inverter must be turned to the "OFF" position.
- 3) For best practice, ensure PV modules of the same model and specifications are connected in each string.
- 4) Make sure the maximum output voltage of each PV string does not exceed 1000V.

2. DC connector assembly procedure

- 1) Select the appropriate photovoltaic cable:

Cable type	Traverse area (mm ²)	
General photovoltaic cable	Range (mm ²)	Recommended value (mm ²)
	2.5-4.0	4.0

- 2) Peel off the DC cable insulation sleeve for 7 mm, as shown in Figure 4-12:

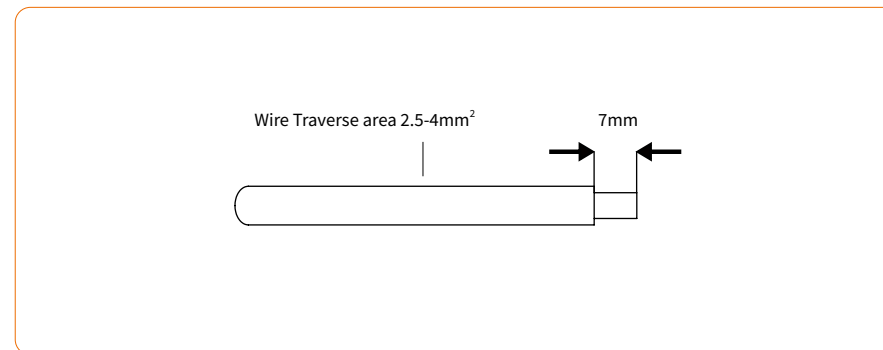

Figure 4-12

3) Disassemble the connector in the accessory bag, as shown in Figure 4-13:

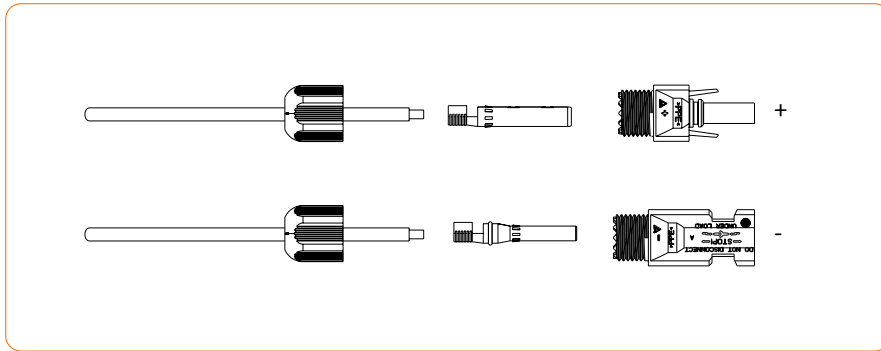

Figure 4-13

4) Insert the DC cable through the DC connector nut into the metal terminal and press the terminal with a professional crimping plier (pull back the cable with some power to check if the terminal is well connected to the cable), as shown in Figure 4-14:

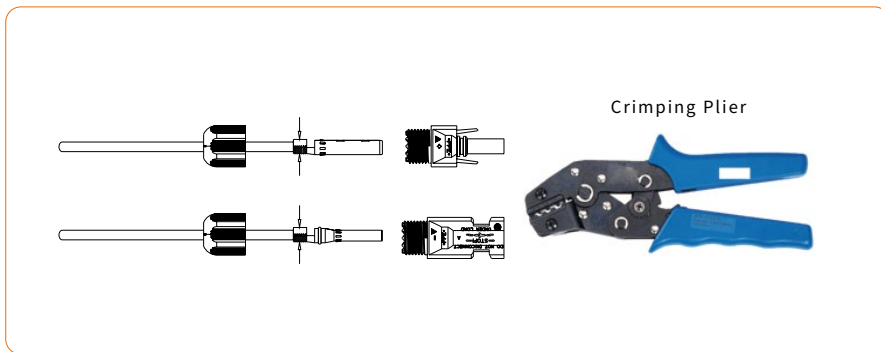

Figure 4-14

5) Insert the positive and negative cables into the corresponding positive and negative connectors, pull back the DC cable to ensure that the terminal is tightly attached in the connector.

6) Use an open-end wrench to screw the nut to the end to ensure that the terminal is well sealed, as shown in Figure 4-15:

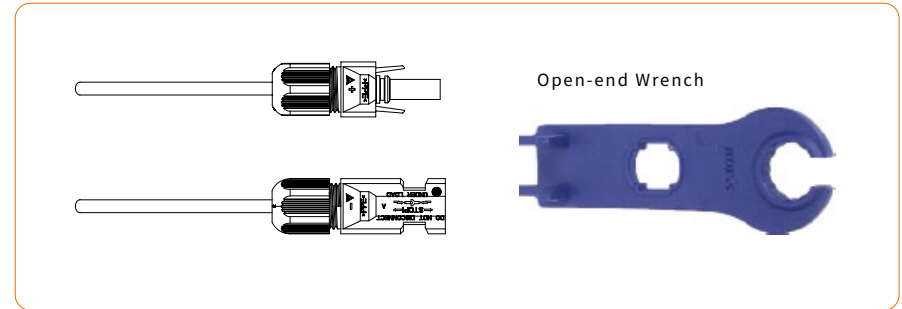

Figure 4-15



Warning

1. Before assembling the DC connector, make sure that the cable polarity is correct.

2. Use a multimeter to measure the voltage of the DC input string, verify the polarity of the DC input cable, and ensure that each string voltage is within 1000V.

3. Insert the positive and negative connectors into the inverter DC input terminals respectively, a “click” sound should be heard if the terminals are well connected, as shown in Figure 4-16:

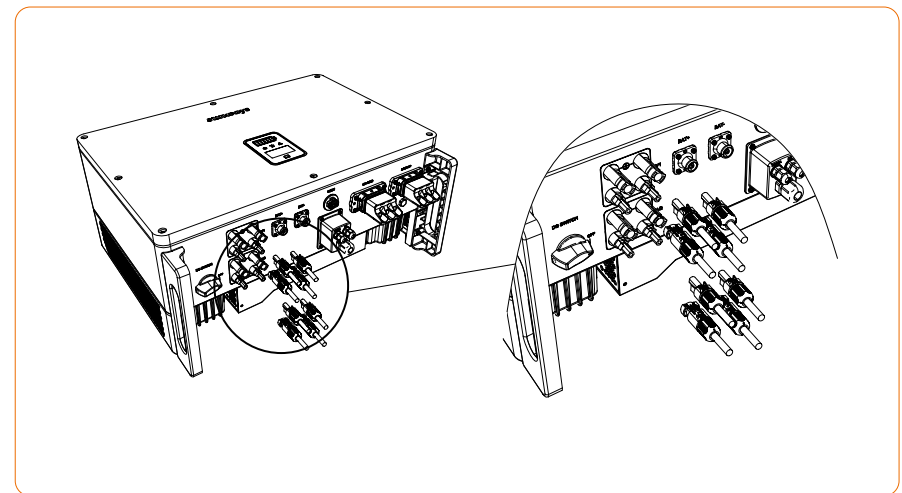

Figure 4-16

▼ 4.3.4 Inverter battery connection

1.The following principles must be considered when making battery connection:

- 1) Disconnect the AC breaker on the grid side.
- 2) Disconnect the breaker on the battery side.
- 3) Turn the inverter DC switch to the “OFF” position.
- 4) Make sure the maximum input voltage of battery is within the inverter limitation (135~800V).

2.Lithium battery connector assembly procedures

- 1) Select an appropriate battery cable

Cable type	Conductor cross-sectional area (mm ²)	
AWG 4	Outside diameter (mm)	Conductor core section (mm ²)
	9-10.5	25

- 2) Peel off the battery cable insulation sleeve for 12 mm, as shown in Figure 4-17:

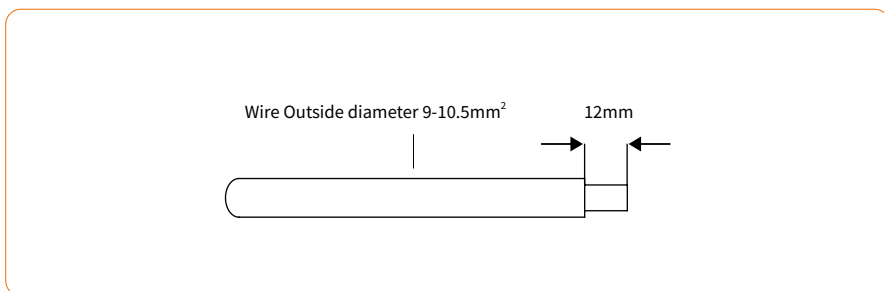

Figure 4-17

- 3) Disassemble the connector in the accessory bag, as shown in Figure 4-18:

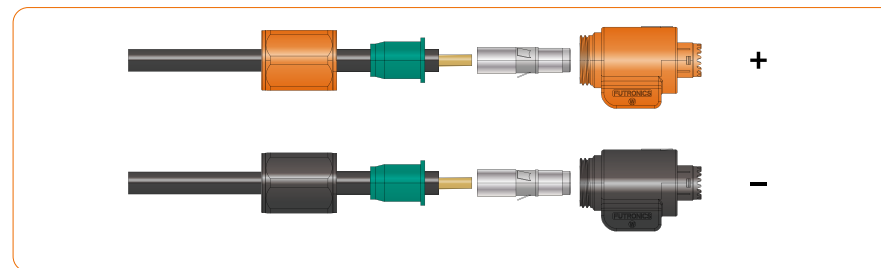

Figure 4-18

- 4) Insert the battery cable through the battery connector nut, then into the metal terminal. Press the terminal with a professional crimping plier (pull back the cable with some power to check if it's tight enough), as shown in Figure 4-19:

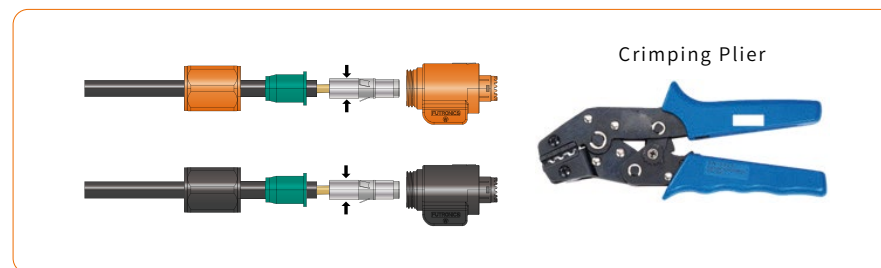

Figure 4-19

Push the metal terminal into the battery connector. Ensure A “click” sound be heard, which mean assembly in place. Screw the battery connectors tightly with hand.



Warning

- 1.Before making the battery connector, please make sure the polarity of the cable is correct.
- 2.Use a multimeter to measure the voltage of the battery pack and make sure the voltage is within the inverter limitation and the polarity is correct.

- 5) Insert the positive and negative connector into the inverter battery terminals respectively. The arrow on connector should point to arrow on the inverter battery terminal. A “click” sound represents the assembly in place, as shown in Figure 4-20:

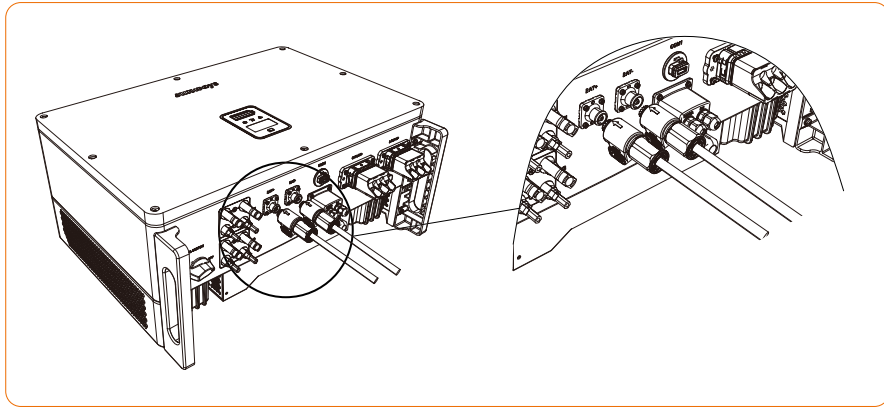

Figure 4-20

1) According to the table above, select an appropriate AC cable, peel off the insulation sleeve of AC cable for 95-100mm, and peel off the sleeve in the conductor core of 3L/PE/N wires for 20-25mm, as shown in Figure 4-21:

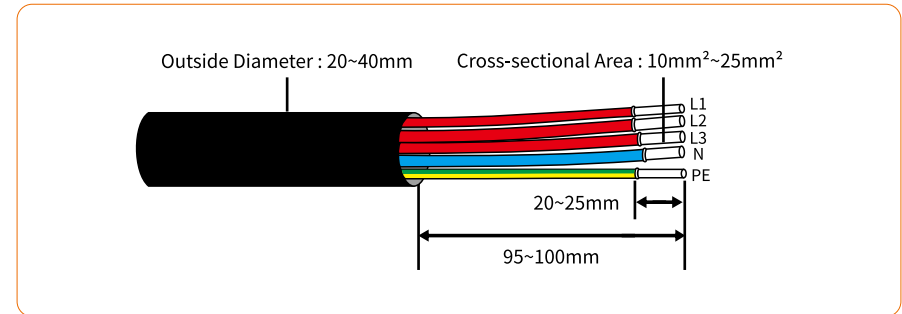

Figure 4-21

2) Thread the stripped wire into the lock nut and the main body in turn (the flexible wire needs to be riveted to the insulated terminal), as shown in Figure 4-22:

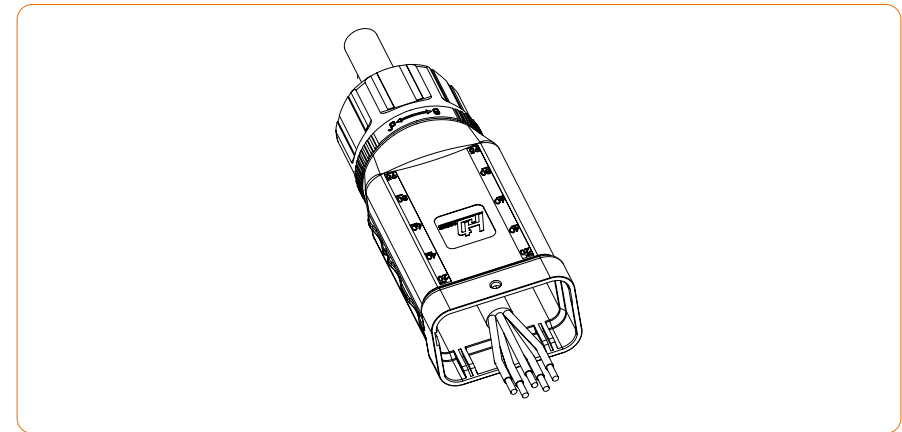

Figure 4-22

▼ 4.3.5 Connection of AC output

1. The following principles must be considered when making AC output connection:
 - 1) An independent AC breaker is required at both on-grid and back-up output side, and any loads cannot be connected with inverter directly.
 - 2) Before making the connection of AC cable, please confirm all DC & AC power source are disconnected from the inverter.
 - 3) Before connecting to the power grid, make sure that the power grid voltage and frequency meet the requirements of the inverter. See technical parameters for details.

2. AC connector assembly procedures

The recommended AC cable and AC breaker for Sunways STH 15~33kW series three-phase hybrid inverter are as shown in the following table:

Model	STH-15KTL-HT	STH-17KTL-HT	STH-20KTL-HT	STH-25KTL-HT	STH-29.9KTL-HT	STH-30KTL-HT	STH-33KTL-HT
Copper Cable Conductor core section (mm ²)	6-10	8-10	8-10	16-25	16-25	16-25	16-25
AC Circuit Breaker (A)	32	40	40	50	63	63	63

3) Insert the cable into the rubber core in the wire sequence, and observe whether the cable is plugged in place through the perspective hole, and finally crimp it with a screwdriver, as shown in Figure 4-23:

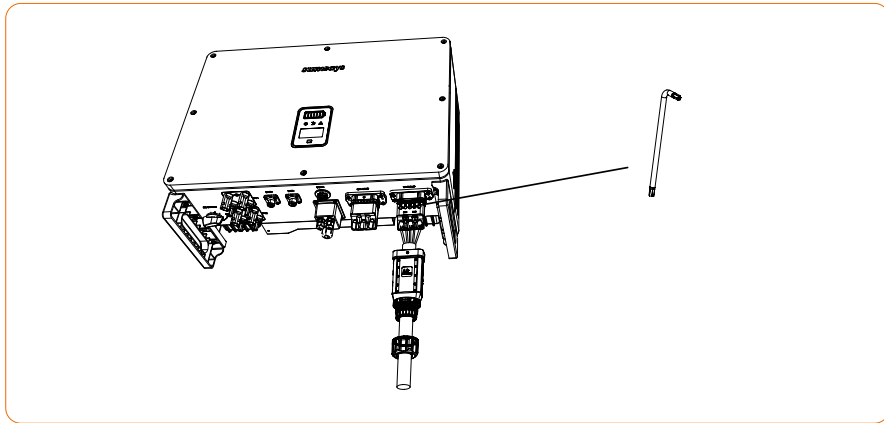

Figure 4-23

4) Insert the flat cable of the display back to its place and put back the right roof cover and lock with its original screws. As shown in Figure 4-24:

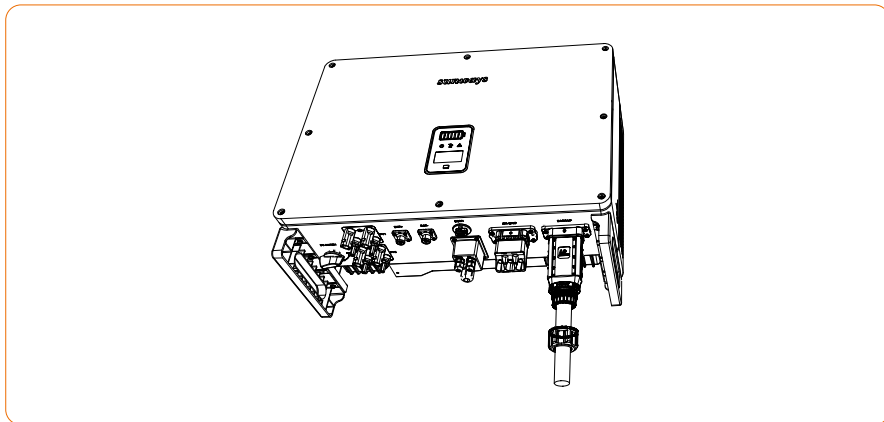

Figure 4-24

5) Tighten the nut with an open ended wrench and complete the installation with a "click, click, click", as shown in Figure 4-25:

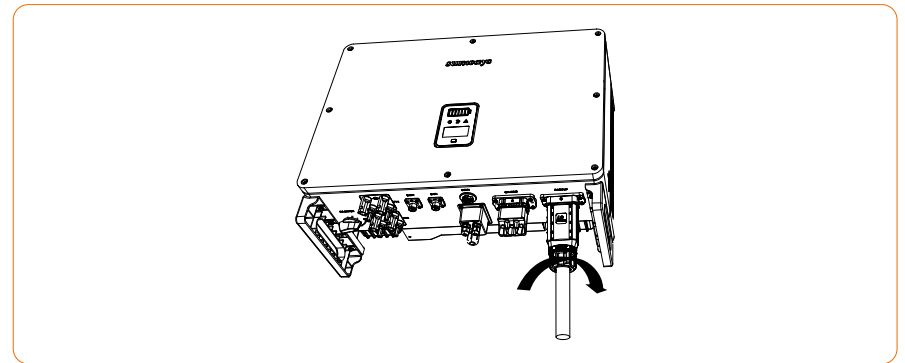

Figure 4-25



Caution

Please distinguish the on-grid and back-up port, and don't mix up the on-grid port and back-up port when making the connection.



Note

It is not necessary to connect PE wires for back-up AC port

※ 4.4 Meter and CT connection

1) The current transducer, also called CT, is usually installed on the fire wires between the house loads and the power grid, as shown in Figure 4-26.

The Meter can be installed in the AC combiner box or other places that are unable to be touched by children. Sunways CTs integrate a cable with length of 2m and could be extended to 5m at max.

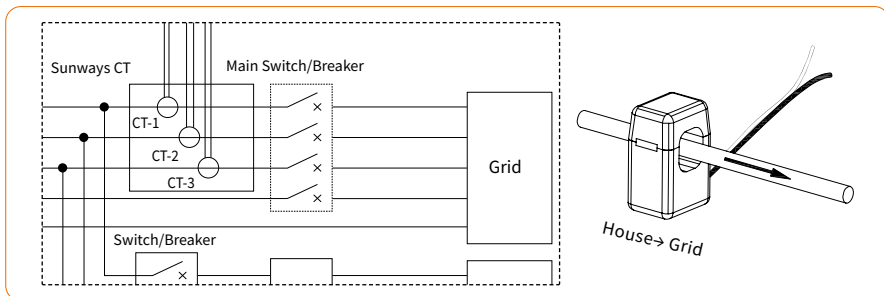

Figure 4-26 CT connection diagram

 Attention	CT installation direction and phase sequence should strictly follow the instruction in the user manual, otherwise, the inverter may not be working normally.
 Attention	The CT has to be corresponding with the port in the meter, and the connection between CT and Meter needs to be reliable, otherwise, the CT measurement accuracy may be affected.
 Note	The rated current of CT in the inverter accessory box is 90A, and the maximum allowed inserted cable diameter is 16mm. If the max current through the CT exceeds the rated current or the cable diameter is wider than 16mm, please contact Sunways for help.

2) The CTs have been connected to the Sunways Meter when you received them, and you just need to follow the wiring diagram in the Meter to connect CT, as shown in Figure 4-27.

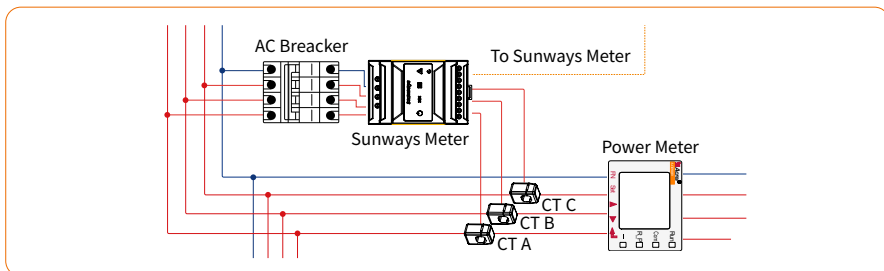

Figure 4-27 Meter wiring diagram

Meter terminals definition as shown in table below:

No.	Definition	Function	No.	Definition	Function
1	L1	L1/L2/L3/N connect to grid to detect power grid voltage	1	L1	L1/L2/L3/N connect to grid to detect power grid voltage
2	L2		2	L2	
3	L3		3	L3	
4	N		4	N	
5	L1-S1	Connect CT to detect current	5	L1-S1	Connect CT to detect current
6	L1-S2		6	L1-S2	
7	L2-S1		7	L2-S1	
8	L2-S2		8	L2-S2	
9	L3-S1		9	L3-S1	
10	L3-S2		10	L3-S2	
12	/	/	12	L	Power supplied from grid
13	/	/	13	N	
RS485-2	RS485	Communicate with inverter	RS485	RS485	Communicate with inverter

Figure 4-28 Meter terminals definition

Please refer to chapter 4.4.2 for the communication between Meter and inverter.

※ 4.5 Communication Connection

▼ 4.5.1 Communication wiring illustration

All communication ports are hidden behind the communication terminal at the bottom of inverter which including Meter port, CAN port, BMS port, EMS port, RLYOUT port, DRED port, as shown in Figure 4-29、 4-30.

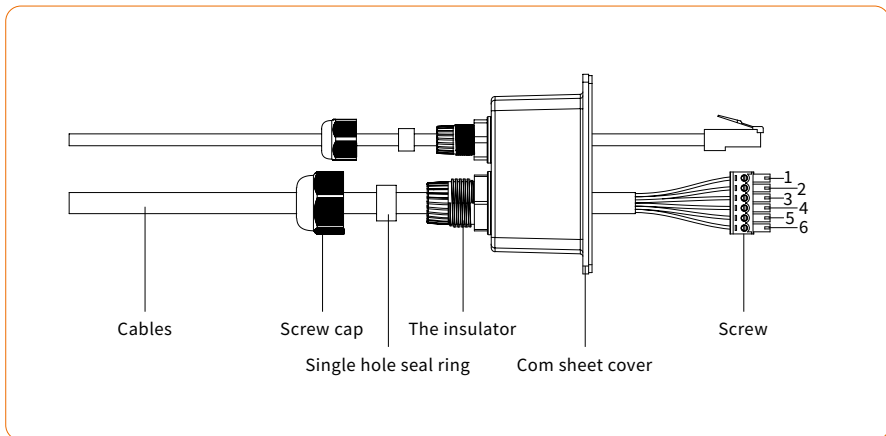

Figure 4-29

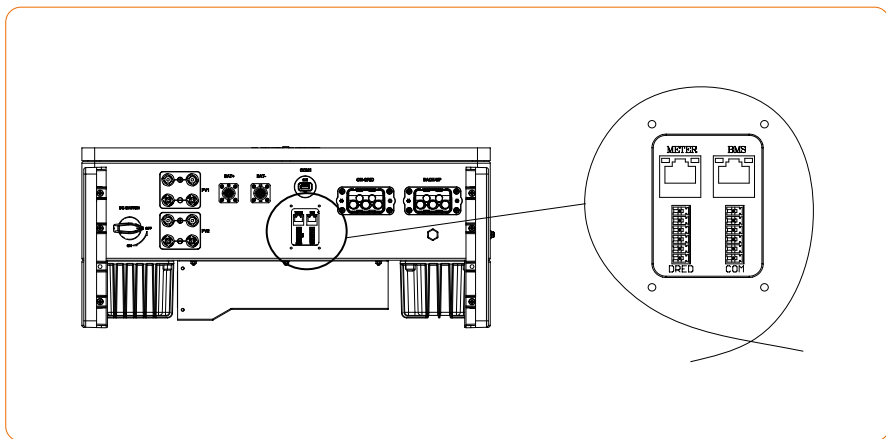

Figure 4-30

Inverter communication interface and definition as shown in table below:

Type	Definition
METER	Communicate with Meter
BMS	Communicate with BMS
DRED	For Australia use/One key to shut off
PARCAN	Parallel CAN communication bus interface
EMS	EMS power dispatching interface
RLYOUT	Dry contact output, a group of normally open contact passive dry contact

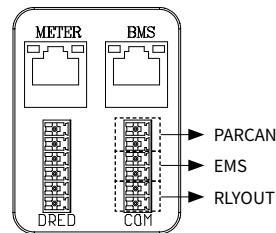

Figure 4-31 Communication terminals definition

Dismantle the cover of the communication ports with a screwdriver, and put all communication cables through the holes and follow the illustration below to make the connection of each communication cables, and when all cables have connected, put back the cover and screw up the anti-water cap of the holes, as shown in Figure 4-32:

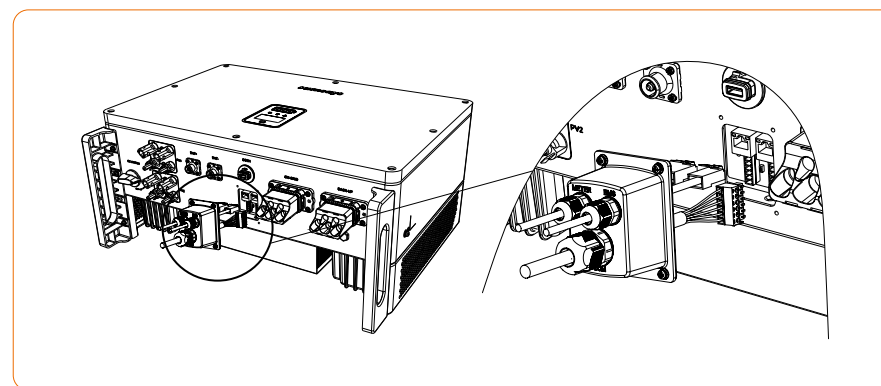

Figure 4-32

▼ 4.5.2 Communication between inverter and meter

The communication between meter and inverter is an RJ45 interface cable. A 10M length meter communication cable is already attached to the inverter when you received it and this cable could be extended up to 100M. Insert the RJ45 heads into the meter RS485 port which as shown in Figure 4-33.

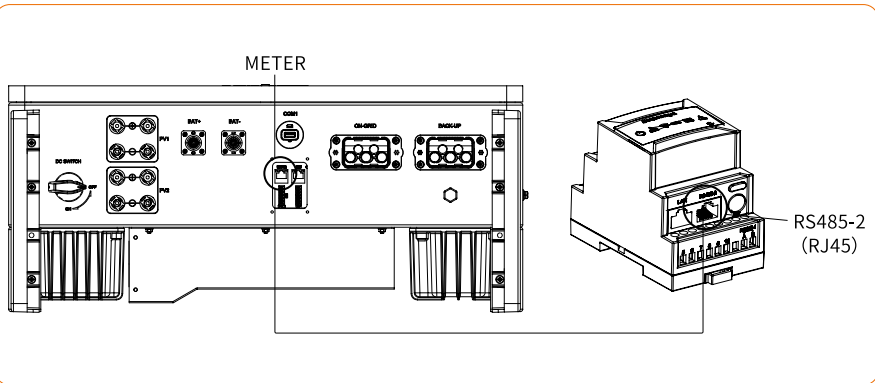
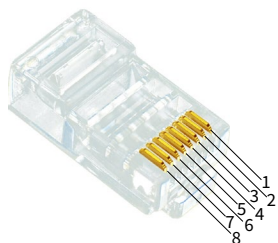

Figure 4-33

RJ45 terminal connection sequence and definition as shown in table 4-34.



No.	Color	Meter Side	Battery Side
1	Orange & White	/	RS485_A
2	Orange	/	RS485_B
3	Green & White	RS485_B	/
4	Blue	/	CAN_H
5	Blue & White	/	CAN_L
6	Green	RS485_A	/
7	Brown & White	RS485_B	/
8	Brown	RS485_A	/

Figure 4-34 RJ45 terminal connection sequence and definition

▼ 4.5.3 Communication between inverter and battery

The communication between meter and inverter is an RJ45 interface cable. A 3M length battery communication cable is already attached to the inverter when you received it, and you just need to insert it to the BMS interface of the inverter and battery.



Note

Before purchasing the battery, you have to make sure the battery you selected is in the battery approval list of Sunways, otherwise, the system may not work properly. Please contact your installer or Sunways service team for confirmation if you're not sure about it.

▼ 4.5.4 Multiple inverters parallel connection/EMS/Relay output dry contact

Multiple inverters parallel connection, EMS and relay output dry contact use the 6pin terminal on the right side, and you can use the matching 6pin terminal in the accessory box to make the connection, as shown in Figure 4-35.

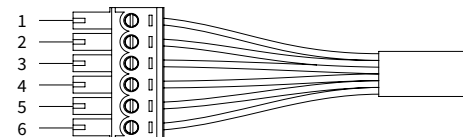

Figure 4-35 Parallel connection/EMS/relay output dry contact terminal

Terminal definition:

No.	1	2	3	4	5	6
Definition	CAN PAR		EMS		RLY OUT	
	CAN_H	CAN_L	RS485_B	RS485_A	RLY_COM	RLY_NO

1) An EMS communication cable needs to be connected when to control the operation of a hybrid inverter through the EMS, and communication between EMS and inverter is RS485.

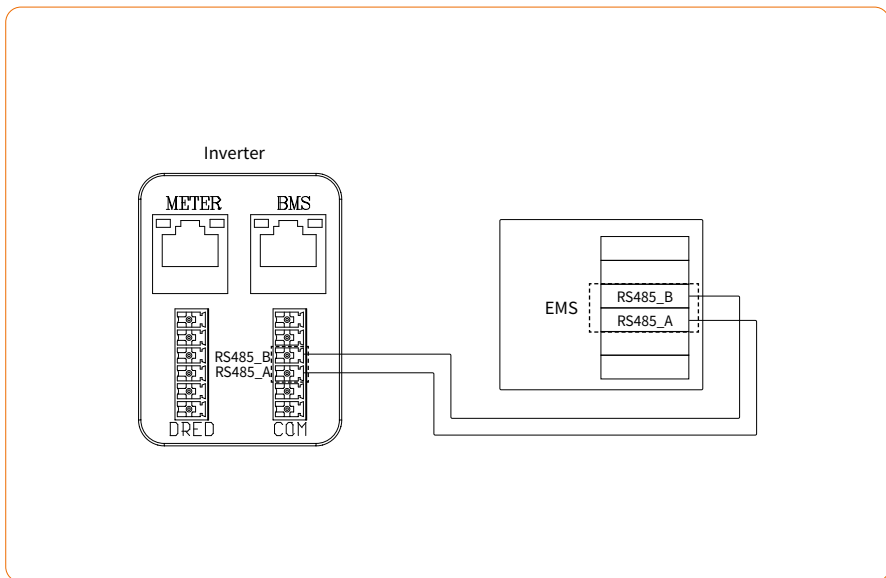

Figure 4-36 EMS communication wiring diagram

2) Sunways STH 15~33kW series hybrid inverter integrated a set of relay output dry contacts with the contact capacity 230Vac/1A or 30Vdc/1A that are very useful in some special circumstances, such as in the purely off-grid system, it can be used to trigger the backup generator. Please contact your installer or Sunways service team to learn more detailed operation steps.

▼ 4.5.5 DRED connection

DRED interface is special reserved for Australia and New Zealand according to their safety regulation, and Sunways doesn't provide the DRED device for the customer.

DRED connection uses the 6pin terminal on the left side, and you can use the matching 6pin terminal in the accessory box to make the connection, as shown in Figure 4-37.

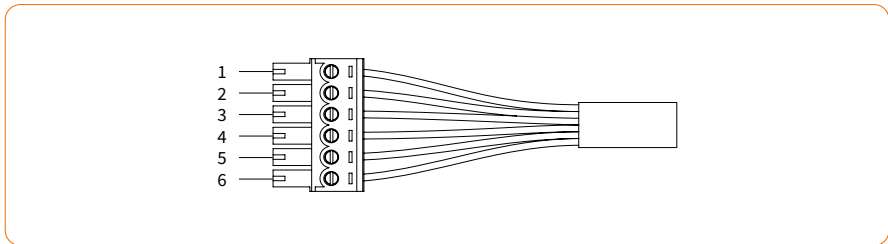

Figure 4-37 DRED terminal

DRED terminal definition:

No.	1	2	3	4	5	6
Definition	COM/DRMO	REFGEN	DRM4/8	DRM3/7	DRM2/6	DRM1/5

▼ 4.5.6 One key to shut off

Sunways STH 15~33kW hybrid inverter comes standard with one key to shut off function, and you can use this function by connecting an external switch into the DRED interface if it requires in the installation place. The external switch doesn't include in our accessory box. Please refer to Figure 4-38 for the external switch connection.

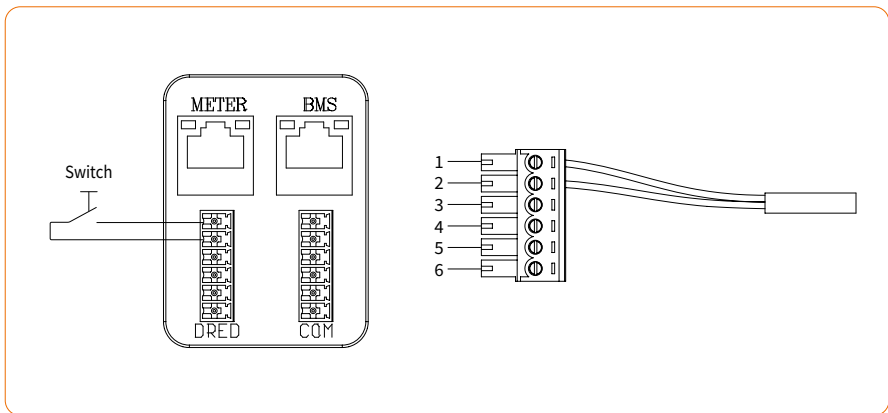

Figure 4-38 One key to shut off terminal

Terminal definition:

No.	1	2	3	4	5	6
Definition	COM/DRMO	REFGEN	/	/	/	/

※ 4.6 Monitoring Device Installation

Sunways STH 15-33kW series hybrid inverter supports WIFI, LAN, and 4G communication.

Plug the WIFI, LAN, or 4G module into the COM1 port in the bottom of inverter (as shown in Figure 4-39). A slight "click" sound during the installation represents that the assembly is in place.

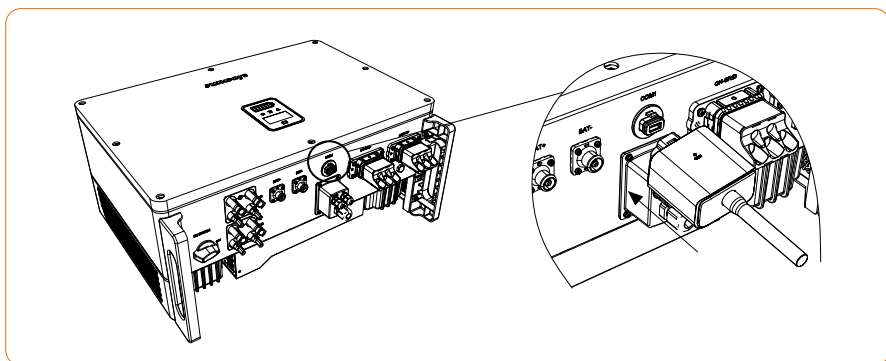

Figure 4-39 Monitoring device installation



Note

- ① The WiFi version module needs to be configured to the router for the first installation. If the router name or password are changed, the WiFi dongle will need to be reconfigured. For details, please refer to the [QUICK INSTALLATION GUIDE].
- ② If DHCP is enabled on the router, the LAN version module does not need to be configured. Otherwise, please refer to the [QUICK INSTALLATION GUIDE].



Attention

Do not touch the waterproof plug in the card slot except for replacing the SIM card. In that case, please make sure the card slot is completely sealed by the weatherproof plug after replacing the SIM card. Any damages caused by improper waterproof plug placement, will void warranty.

» 5 Start and Stop

※ 5.1 Start the Inverter

When starting the inverter, follow these steps:

- 1) Turn on the AC breaker first (close the AC circuit breaker).
- 2) Turn the DC switch in the inverter bottom to the "ON" position.
- 3) Turn on the lithium battery switch.
- 4) The inverter will start to check the DC and AC input parameters and self-check, and if everything is normal, the inverter will start to work according to the work mode which you set on the App. The inverter display and indicators will show relative parameters and status.

※ 5.2 Stop the Inverter

When turning off the inverter, please follow the steps below:

- 1) Shut off the inverter through the APP or the button on the display first.
- 2) Disconnect the breakers on the grid and load side.
- 3) Turn off the battery switch, and disconnect the DC breaker on the battery side (if any).
- 4) Wait 30 seconds and then turn the inverter DC switch to the "OFF" position. At this time, there is remaining power in the inverter capacitor. Wait for 5 minutes until the inverter is completely de-energized before operating.
- 5) Disconnect the AC and DC cables.

6 General Operation

6.1 Display Operation

When the inverter is turned on, the following interfaces will be displayed on the OLED display, and the OLED display allows the user to check various operation information and to modify the settings of the inverter. Please refer to the following display operation flow for details:

6.1.1 Main window and general setting

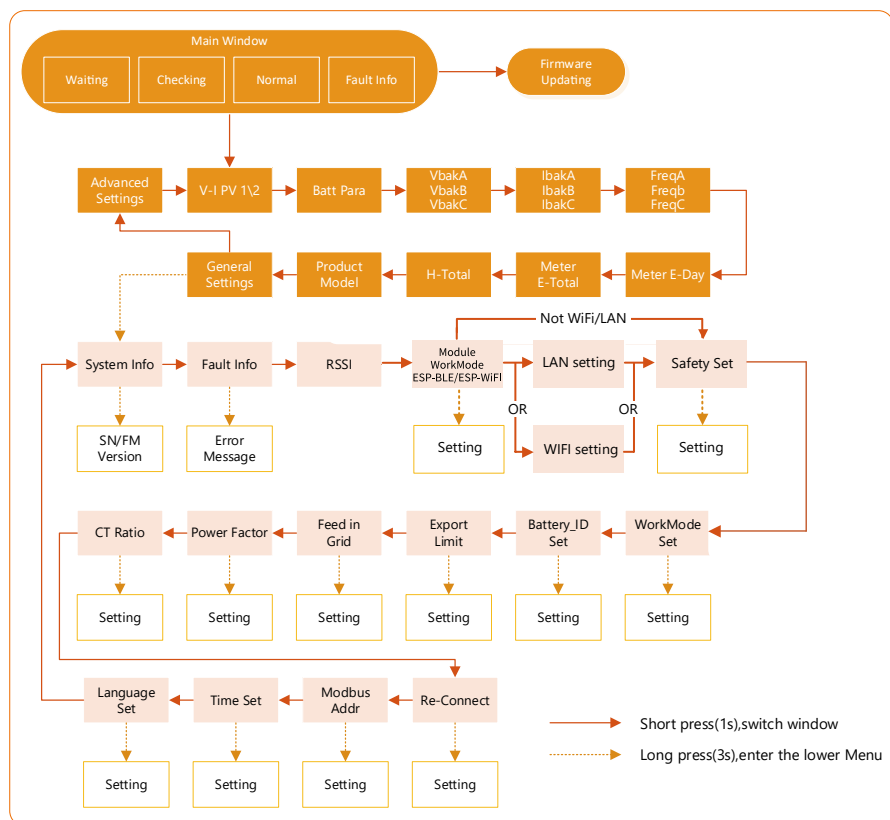

Please wait for 10seconds and the inverter will automatically save your settings or modifications.

6.1.2 LAN/WIFI Setting

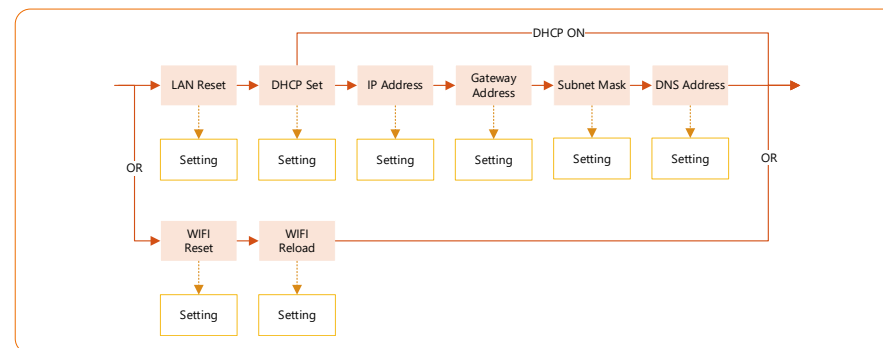

6.1.3 Advanced Setting

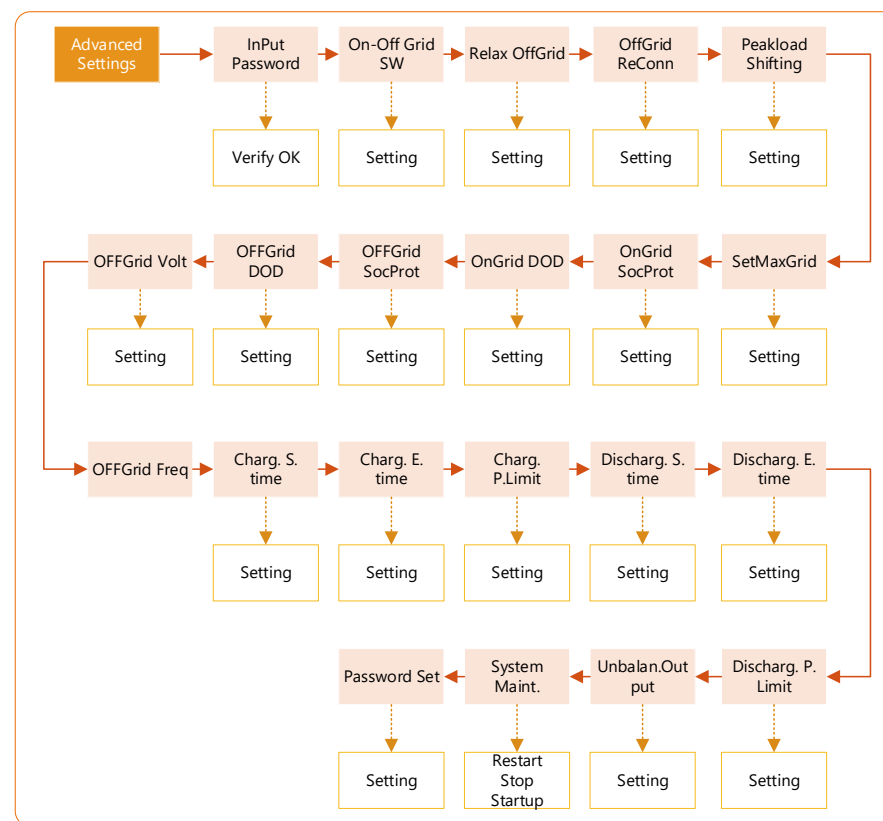

Inverter Display Abbreviation and Complete Name Reference Table

Abbreviation	Complete Name
Work Mode	Current Work Mode / Work Mode Setting
Peakload Shifting	Peakload Shifting Function Switch
SetMaxGrid kVA	Set max allowed power from grid (under the condition of Peakload Shifting is on)
OnGrid SocProt.	OnGrid Battery Soc Protection
OnGrid DOD	OnGrid Discharge of Depth
OffGrid SocProt.	OffGrid Soc Protection
OffGrid DOD	OffGrid Discharge of Depth
OffGrid Volt	OffGrid Voltage Setting
OffGrid Freq	OffGrid Frequency Setting
Discharg.S.time	Discharge Start Time (Available in Economic Mode)
Discharg.E.time	Discharge End Time (Available in Economic Mode)
Discharg.P.Lim.	Discharge Power Limit (Available in Economic Mode)
Charg. S.time	Charge Start Time (Available in Economic Mode)
Charg. E.time	Charge End Time (Available in Economic Mode)
Charg. P.Lim.	Charge Power Limit (Available in Economic Mode)
Unbalan. Output	OnGrid 3-Phase Unbalanced Output Switch
On-Off Grid SW	Off-grid Function SW (Inverter will automatically switch to off-grid mode to ensure the back-up side power supply when the grid is abnormal or off)
Relax OffGrid	Reduce the switching sensitivity of the On/Off-grid (applied to the places where the grid is unstable or inverter always entered off-grid mode for some reasons)
OffGrid ReConn.	When the power grid is off, the inverter can automatically restart the back-up output after a fault or overloading protection occurred if the Off-grid Restart is ON. Otherwise, the back-up output needs to be restarted manually
FW Updating	Firmware Updating

Abbreviation	Complete Name
E-Day	Daily Energy Generation
E-Total	Total Energy Generation
H-Total	Total Generating Hours
System Info	System Information
FW Version	Firmware Version
SN	Series Number
Fault Info	Fault Information
RSSI	Received Signal Strength Indicator
WiFi Reset	WiFi Reset
WiFi Reld	WiFi Reload, to reload the WiFi module to factory settings
LAN Reset	LAN Reset
DHCP Set	Enable or disable DHCP functionality
IP Address	If DHCP is turned off, set the static IP Address
Gateway Address	If DHCP is turned off, set the Gateway IP Address
Subnet Mask	If DHCP is turned off, set the Subnet Mask
DNS Address	If DHCP is turned off, set the Domain Name Server Address
Export Limit	On-Grid Export Limit Function Switch
Feed in Grid	Set the percentage of the power that is allowed to feed to the grid
Re-Conect	Fault Reconnection Time
CT Ratio	Current Transformer Ratio Setting
Modbus Addr	Modbus Address Setting
Battery_ID Set	Set Battery Model
System Maint.	System maintenance, includes inverter stop and run, system restart

※ 6.2 Country Code (Safety Code) Setting

Please set "Country code (Safety code)" under the menu "Safety Set" in "General Settings".

Please follow this flow chart to set "Country code (Safety code)":

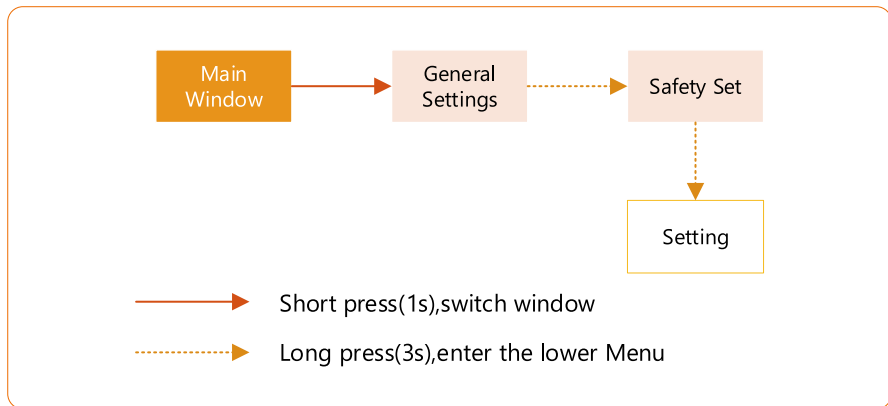

※ 6.3 Auto-Test

This function is disabled by default, and will be only functional in the safety code of Italy. Short press the button several times until "Auto Test CEI 0-21" displays on the screen, press and hold the button 3 seconds to activate "Auto Test". After the auto test is finished, short press the button several times until the screen displays "Auto Test Record", and hold the button 3 seconds to check the test results.

Connect the AC cable, auto test will start after the inverter connected to the grid, see the operation steps below:

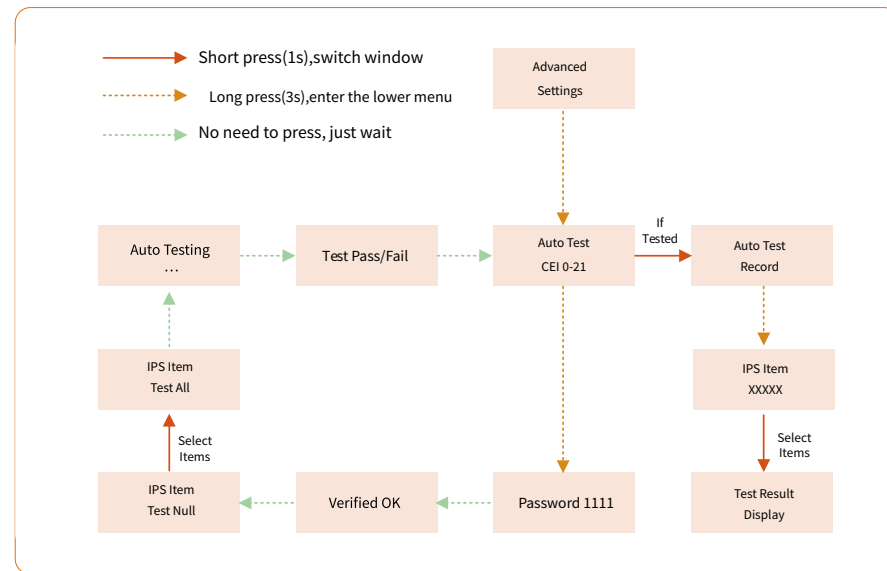

The auto test will start when the correct test item is selected, and the test result will be displayed on the screen when it finished. If the test was successful, it will display "Test Pass", otherwise will display "Test Fail". After each item tested, the inverter will reconnect to the grid and automatically start the next test according to the requirements of CEI 0-21.

※ 6.4 Online Monitoring APP

Sunways inverter provides a monitoring port that can collect and transmit data from the inverter to Sunways monitoring platform via an external monitoring device. Please refer to the product nameplate on side of enclosure to get the monitoring application. If download issues exist, contact your dealer or Sunways technical support.

» 7 Troubleshooting

※ 7.1 Error Message

Sunways STH 15-33kW series hybrid inverter is designed in accordance with grid operation standards, and conform to the requirements of safety and EMC. The inverter had passed a series of rigorous tests to ensure it runs sustainably and reliably before shipment.

When a fault occurs, the corresponding error message will be shown on the OLED display, and in this case, the inverter might stop feeding into grid. The fault messages and their corresponding troubleshooting methods are listed below:

Error Message	Description	Solution
Mains Lost	Grid power outage, AC switch or circuit is disconnected.	<ol style="list-style-type: none"> 1. Check whether the mains supply is lost. 2. Check whether the AC breaker and terminal are well connected.
Grid Voltage Fault	Grid overvoltage or undervoltage, the grid voltage is higher or lower than the set protection value.	<ol style="list-style-type: none"> 1. Check whether the impedance of the AC cable is too high to lead the grid voltage increased. Change a thicker AC cable if it is. 2. Extend the voltage protection range if it is allowed by the electricity company.
Grid Frequency Fault	Grid over frequency or underfrequency, the grid frequency is higher or lower than the set protection value.	<ol style="list-style-type: none"> 1. Check whether the AC cable is correct and well connected. 2. Change to another country with wider protection range if it's allowed by the local electricity company.
DCI Fault	DC injection High. Inverter detects a higher DC component in AC output.	<ol style="list-style-type: none"> 1. Restart the inverter. 2. Seek for help from the installer or manufacture.





Error Message	Description	Solution
ISO Over Limitation	Low system insulation resistance, which is generally caused by poor insulation to ground of the module/cable or by rainy and damp environment.	<ol style="list-style-type: none"> 1. Restart the inverter. 2. Check if the insulation of the wires in PV, battery, and AC is damaged. Seek for help from the installer or manufacture.
GFCI Fault	Excessive leakage current.	<ol style="list-style-type: none"> 1. Restart the inverter. 2. Check if the insulation of the wires in PV, battery, and AC is damaged. 3. Seek for help from the installer or manufacture.
PV Over Voltage	PV over voltage is too high.	<ol style="list-style-type: none"> 1. Reduce the number of PV panels to make sure the open-circuit voltage of each string is lower than the inverter max allowed input voltage.
Bus Voltage Fault	BUS voltage is over-high.	<ol style="list-style-type: none"> 1. Check whether the input voltage is over the limitation. 2. Seek for help from the installer or manufacture.
Inverter Over Temperature	Temperature anomaly, the temperature of the interior of the inverter is excessively high and out of the safe range.	<ol style="list-style-type: none"> 1. Check if the heat dissipation of the inverter is normal. 2. Seek for help from the installer or manufacture.
SPI Fault	Internal communication fails. Caused by a strong external magnetic field etc.	<ol style="list-style-type: none"> 1. Restart the inverter. 2. Seek for help from the installer or manufacture.
E2 Fault	Internal storage anomaly. Caused by a strong external magnetic field etc.	<ol style="list-style-type: none"> 1. Restart the inverter. 2. Seek for help from the installer or manufacture.

Error Message	Description	Solution
GFCI Device Fault	GFCI device anomaly.	<ol style="list-style-type: none"> 1. Restart the inverter. 2. Seek for help from the installer or manufacture.
AC Transducer Fault	AC transducer anomaly.	<ol style="list-style-type: none"> 1. Restart the inverter. 2. Seek for help from the installer or manufacture.
Relay Check Fail	Self-checking of relay fails. neutral & ground cable are not connected well on AC side or just occasional failure.	<ol style="list-style-type: none"> 1. Check use multi-meter if there is high voltage (normally should be lower than 10V) between N&PE cable on AC side. If the voltage higher than 10V, it means the Neutral & ground cable are not connected well on AC side or restart inverter. 2. If the neutral & ground cable are connected well, please contact Sunways.
Internal Fan Fault	Internal fan anomaly.	<ol style="list-style-type: none"> 1. Restart the inverter. 2. Seek for help from the installer or manufacture.
External Fan Fault	External fan anomaly.	<ol style="list-style-type: none"> 1. Stop the inverter and disconnect the AC&DC cables. 2. Check whether the fan is blocked by foreign matters. If not, replace the fan.
Bus Voltage Hard Fault	BUS voltage is over-high	<ol style="list-style-type: none"> 1. Restart the inverter. 2. Seek for help from the installer or manufacture.

Error Message	Description	Solution
PV Power Low	PV power Low.	<ol style="list-style-type: none"> 1. Check if part of the PV array is sheltered. 2. Check if the sunlight is sufficient at the PV installed area.
Bat OV	Battery voltage is too high.	<ol style="list-style-type: none"> 1. Check whether the battery voltage exceeds the upper limit of the battery. 2. Check battery terminal wiring.
Backup OV	Backup output voltage is too high.	<ol style="list-style-type: none"> 1. Restart the inverter. 2. Check the inverter Backup side wiring.
Bus Volt Low	Bus voltage is too low.	<ol style="list-style-type: none"> 1. Restart the inverter. 2. Seek for help from the installer or manufacture.
Hard Fault	Other faults.	<ol style="list-style-type: none"> 1. Restart the inverter. 2. Seek for help from the installer or manufacture.
Backup OP	Backup output overload.	<ol style="list-style-type: none"> 1. Reduce loads connected in the Backup side. 2. Restart the inverter.
Inverter OV	Backup output overvoltage.	<ol style="list-style-type: none"> 1. Restart the inverter. 2. Seek for help from the installer or manufacture.

Error Message	Description	Solution
Inverter OF	Backup output over frequency.	<ol style="list-style-type: none"> 1. Restart the inverter. 2. Seek for help from the installer or manufacture.
Inverter OC	Backup output overcurrent.	<ol style="list-style-type: none"> 1. Restart the inverter. 2. Seek for help from the installer or manufacture.
Phase Order Err	phase sequence error.	<ol style="list-style-type: none"> 1. Restart the inverter. 2. Seek for help from the installer or manufacture.
SCI Fault	Internal communication fails. Caused by a strong external magnetic field etc.	<ol style="list-style-type: none"> 1. Restart the inverter. 2. Seek for help from the installer or manufacture.
FLASH Fault	Internal storage anomaly. Caused by a strong external magnetic field etc.	<ol style="list-style-type: none"> 1. Restart the inverter. Seek for help from the installer or manufacture.
Meter Comm Fault	Inverter and meter communication abnormal.	<ol style="list-style-type: none"> 1. Check the Meter wiring. 2. Check whether the Meter is normal.
Battery Fault	Battery fault.	<ol style="list-style-type: none"> 1. Restart the inverter. 2. Seek for help from the installer or manufacture.

※ 7.2 Maintenance

 Danger	Risk of inverter damage or personal injury due to incorrect service! Always keep in mind that the inverter is powered by dual sources: PV strings and utility grid. Before any service work, observe the following procedure. <ol style="list-style-type: none"> 1. Disconnect the AC circuit breaker and then set the DC load-break switch of the inverter to OFF; 2. Wait at least 5 minutes for inner capacitors to discharge completely; 3. Verify that there is no voltage or current before pulling any connector.
 Caution	Keep non-qualified persons away! A temporary warning sign or barrier must be posted to keep non-qualified persons away while performing electrical connection and service work.
 Attention	Restart the inverter only after removing the fault that impairs safety performance. Never arbitrarily replace any internal components. For any maintenance support, please contact Sunways. Otherwise, Sunways shall not be held liable for any damage caused.
 Note	Servicing of the device in accordance with the manual should never be undertaken in the absence of proper tools, test equipment or the latest revision of the manual which has been clearly and thoroughly understood.

Items	Methods	Period
System clean	Check the temperature and dust of the inverter. Clean the inverter enclosure if necessary. Check if the air inlet and outlet are normal. Clean the air inlet and outlet if necessary.	Six months to a year (it depends on the dust contents in air.)

8 Technical Parameters

Model	STH-15KTL-HT	STH-17KTL-HT	STH-20KTL-HT	STH-25KTL-HT
PV Input				
Max. Input Power (W)	22,500	25,500	30,000	37,500
Start-up Voltage (V)	190	190	190	190
Max. DC Input Voltage (V)	1000	1000	1000	1000
Rated DC Input Voltage (V)	620	620	620	620
MPPT Voltage Range (V)	200-850	200-850	200-850	200-850
Number of MPP Trackers	2	2	2	2
Number of DC Inputs per MPPT	2	2	2	2
Max. Input Current (A)	32/32	32/32	32/32	32/32
Max. Short-circuit Current (A)	40/40	40/40	40/40	40/40
backfeed current to the array (A)	0	0	0	0
Battery				
Battery Type	Lithium battery (with BMS)			
Battery communication mode	CAN / RS485			
Battery voltage range (V)	200-800			
Maximum charging current (A)	50			
Maximum discharge current (A)	50			
Rated current of built-in fuse (A)	125			
Output(Grid)				
Rated Output Power (W)	15,000	17,000	20,000	25,000
Max. Output Power (W)	16,500	18,700	22,000	27,500
AC output rated apparent power (VA)	15,000	17,000	20,000	25,000
Max. Input Apparent Power (VA)	22,500 ^①	25,500 ^①	30,000 ^①	37,500 ^①
Rated Output Voltage (V)	3L / N / PE, 230 (400)			
Rated AC Frequency (Hz)	50/60	50/60	50/60	50/60
AC output rated current (A)	21.7	24.6	29.0	36.2
Max. Output Current (A)	25.0	28.3	33.3	41.7
Power Factor	0.8 leading ... 0.8 lagging			
Max. total harmonic distortion	<3% @Rated Output Power			
DCI	<0.5%ln			
Output(Back-up)				
Rated Output Power (W)	15,000	17,000	20,000	25,000
Max. Output Power (W)	16,500	18,700	22,000	27,500
Back-up output rated apparent power (VA)	15,000	17,000	20,000	25,000
Max. Apparent Power (VA)	16,500	18,700	22,000	27,500
Back-up output rated current (A)	21.7	24.6	29.0	36.2
Max. Output Current (A)	25.0	28.3	33.3	41.7
UPS switching time	<10ms	<10ms	<10ms	<10ms
Rated Output Voltage (V)	3L/N/PE, 230 (400)			
Rated AC Frequency (Hz)	50/60	50/60	50/60	50/60
Voltage harmonic distortion	<3% @Linear load			

① Max apparent power from the grid means the maximum power imported from the utility grid used to satisfy the backup loads and charge the battery.

Model	STH-15KTL-HT	STH-17KTL-HT	STH-20KTL-HT	STH-25KTL-HT
Efficiency				
Max. Efficiency	98.1%	98.1%	98.1%	98.2%
European Efficiency	97.3%	97.3%	97.3%	97.4%
MPPT Efficiency	99.9%	99.9%	99.9%	99.9%
Max battery charging conversion efficiency	97.2%	97.2%	97.2%	97.3%
Max battery discharge conversion efficiency	97.2%	97.2%	97.2%	97.3%
Protection				
DC Reverse Polarity Protection	Integrated			
Battery input reverse connection protection	Integrated			
Insulation Resistance Protection	Integrated			
DC Switch	Optional			
Surge Protection	Integrated			
Over-temperature Protection	Integrated			
Residual Current Protection	Integrated			
Anti-islanding protection	Frequency shift, Integrated			
AC Over-voltage Protection	Integrated			
overload protection	Integrated			
AC Short-circuit Protection	Integrated			
General Data				
Over voltage category	PV: II ; Main: III			
Dimensions (mm)	600W*400H*280D			
Weight (kg)	45			
Protection Degree	IP65			
Self-consumption at Night (W)	<15			
Topology	Transformer less			
Operating Temperature Range (°C)	-30~60			
Relative Humidity (%)	0~100			
Operating Altitude (m)	3000			
Cooling	Smart Fan Cooling			
Noise Level (dB)	<50			
Display	OLED & LED			
Communication	WiFi/LAN (Optional)			
Compliance				
IEC62109、IEC62116、VDE4105、VDE0126、AS4777、RD1699、NBR16149、IEC61727、IEC60068、IEC61683、EN50549、EN61000、NRS097-2-1、IEC/EN 62477-1				

Model	STH-29.9KTL-HT	STH-30KTL-HT	STH-33KTL-HT
PV Input			
Max. Input Power (W)	44,850	45,000	49,500
Start-up Voltage (V)	190	190	190
Max. DC Input Voltage (V)	1000	1000	1000
Rated DC Input Voltage (V)	620	620	620
MPPT Voltage Range (V)	200-850	200-850	200-850
Number of MPP Trackers	2	2	2
Number of DC Inputs per MPPT	2	2	2
Max. Input Current (A)	32/32	32/32	32/32
Max. Short-circuit Current (A)	40/40	40/40	40/40
backfeed current to the array (A)	0	0	0
Battery			
Battery Type	Lithium battery (with BMS)		
Battery communication mode	CAN / RS485		
Battery voltage range (V)	200-800		
Maximum charging current (A)	50		
Maximum discharge current (A)	50		
Rated current of built-in fuse (A)	125		
Output(Grid)			
Rated Output Power (W)	29,900	30,000	33,000
Max. Output Power (W)	29,900	33,000	36,300
AC output rated apparent power (VA)	29,900	30,000	33,000
Max. Input Apparent Power (VA)	44,850 ^①	45,000 ^①	42,000 ^①
Rated Output Voltage (V)	3L / N / PE, 230 (400)		
Rated AC Frequency (Hz)	50/60	50/60	50/60
AC output rated current (A)	43.3	43.5	47.8
Max. Output Current (A)	49.8	50.0	55.0
Power Factor	0.8 leading ...0.8 lagging		
Max. total harmonic distortion	<3% @Rated Output Power		
DCI	<0.5%In		
Output(Back-up)			
Rated Output Power (W)	29,900	30,000	33,000
Max. Output Power (W)	29,900	33,000	36,300
Back-up output rated apparent power (VA)	29,900	30,000	33,000
Max. Apparent Power (VA)	29,900	33,000	36,300
Back-up output rated current (A)	43.3	43.5	47.8
Max. Output Current (A)	49.8	50.0	55.0
UPS switching time	<10ms	<10ms	<10ms
Rated Output Voltage (V)	3L/N/PE, 230 (400)		
Rated AC Frequency (Hz)	50/60	50/60	50/60
Voltage harmonic distortion	<3% @Linear load		

① Max apparent power from the grid means the maximum power imported from the utility grid used to satisfy the backup loads and charge the battery.

Model	STH-29.9KTL-HT	STH-30KTL-HT	STH-33KTL-HT
Efficiency			
Max. Efficiency	98.1%	98.1%	98.1%
European Efficiency	97.3%	97.3%	97.3%
MPPT Efficiency	99.9%	99.9%	99.9%
Max battery charging conversion efficiency	97.2%	97.2%	97.2%
Max battery discharge conversion efficiency	97.2%	97.2%	97.2%
Protection			
DC Reverse Polarity Protection	Integrated		
Battery input reverse connection protection	Integrated		
Insulation Resistance Protection	Integrated		
DC Switch	Optional		
Surge Protection	Integrated		
Over-temperature Protection	Integrated		
Residual Current Protection	Integrated		
Anti-islanding protection	Frequency shift, Integrated		
AC Over-voltage Protection	Integrated		
overload protection	Integrated		
AC Short-circuit Protection	Integrated		
General Data			
Over voltage category	PV: II ; Main: III		
Dimensions (mm)	600W*400H*280D		
Weight (kg)	45		
Protection Degree	IP65		
Self-consumption at Night (W)	<15		
Topology	Transformer less		
Operating Temperature Range (°C)	-30~60		
Relative Humidity (%)	0~100		
Operating Altitude (m)	3000		
Cooling	Smart Fan Cooling		
Noise Level (dB)	<50		
Display	OLED & LED		
Communication	WiFi/LAN (Optional)		
Compliance			
IEC62109、IEC62116、VDE4105、VDE0126、AS4777、RD1699、NBR16149、IEC61727、IEC60068、IEC61683、EN50549、EN61000、NRS097-2-1、IEC/EN 62477-1			



sunways

 No. 1, Second Road, Green Industrial Zone, Chongshou Town,
Cixi City, ZheJiang Province, PRC

 www.sunways-tech.com

 service@sunways-tech.com